

### Nominal data

Type	S4E400-AQ12-57	
Motor	M4E074-DF	
Phase		1~
Nominal voltage	VAC	230
Frequency	Hz	50
Type of data definition		fa
Valid for approval / standard		CE
Speed	min <sup>-1</sup>	1400
Power input	W	150
Current draw	A	0.66
Motor capacitor	μF	5
Capacitor voltage	VDB	400
Max. back pressure	Pa	70
Min. ambient temperature	°C	-40
Max. ambient temperature	°C	40

ml = Max. load · me = Max. efficiency · fa = Running at free air · cs = Customer specs · cu = Customer unit  
Subject to alterations

### Data according to ErP directive

Installation category	A
Efficiency category	Static
Variable speed drive	No
Specific ratio*	1.00

\* Specific ratio =  $1 + p_{fs} / 100\,000 \text{ Pa}$

		Actual	Request 2013	Request 2015
Overall efficiency $\eta_{es}$	%	29	25	29
Efficiency grade N		40	36	40
Power input $P_e$	kW	0.18		
Air flow $q_v$	m <sup>3</sup> /h	2790		
Pressure increase $p_{fs}$	Pa	70		
Speed n	min <sup>-1</sup>	1335		

Data definition with optimum efficiency. LU-33842  
The ErP data is determined using a motor-impeller combination in a standardised measurement configuration.

# AC axial fan

sickled blades (S series)  
with guard grille for short nozzle

## Technical features

<b>Mass</b>	5.63 kg
<b>Size</b>	400 mm
<b>Surface of rotor</b>	Coated in black
<b>Material of terminal box</b>	ABS plastic
<b>Material of blades</b>	Sheet steel, coated in black
<b>Number of blades</b>	5
<b>Direction of air flow</b>	"V"
<b>Direction of rotation</b>	Counter-clockwise, seen on rotor
<b>Type of protection</b>	IP 44; Depending on installation and position as per EN 60034-5
<b>Insulation class</b>	"B"
<b>Humidity class</b>	F2-2
<b>Max. permissible ambient motor temp. (transp./ storage)</b>	+ 70 °C
<b>Min. permissible ambient motor temp. (transp./storage)</b>	- 40 °C
<b>Mounting position</b>	Shaft horizontal or rotor on bottom; rotor on top on request
<b>Condensate discharge holes</b>	Rotor-side
<b>Operation mode</b>	S1
<b>Motor bearing</b>	Ball bearing with anti-freezing grease
<b>Touch current acc. IEC 60990 (measuring network Fig. 4, TN system)</b>	< 0.75 mA
<b>Electrical leads</b>	Via terminal box, integrated capacitor connected via terminal box
<b>Motor protection</b>	Thermal overload protector (TOP) wired internally
<b>Cable exit</b>	Variable
<b>Protection class</b>	I (if protective earth is connected by customer)
<b>Product conforming to standard</b>	EN 60335-1; CE

# AC axial fan

sickled blades (S series)  
with guard grille for short nozzle

## Product drawing

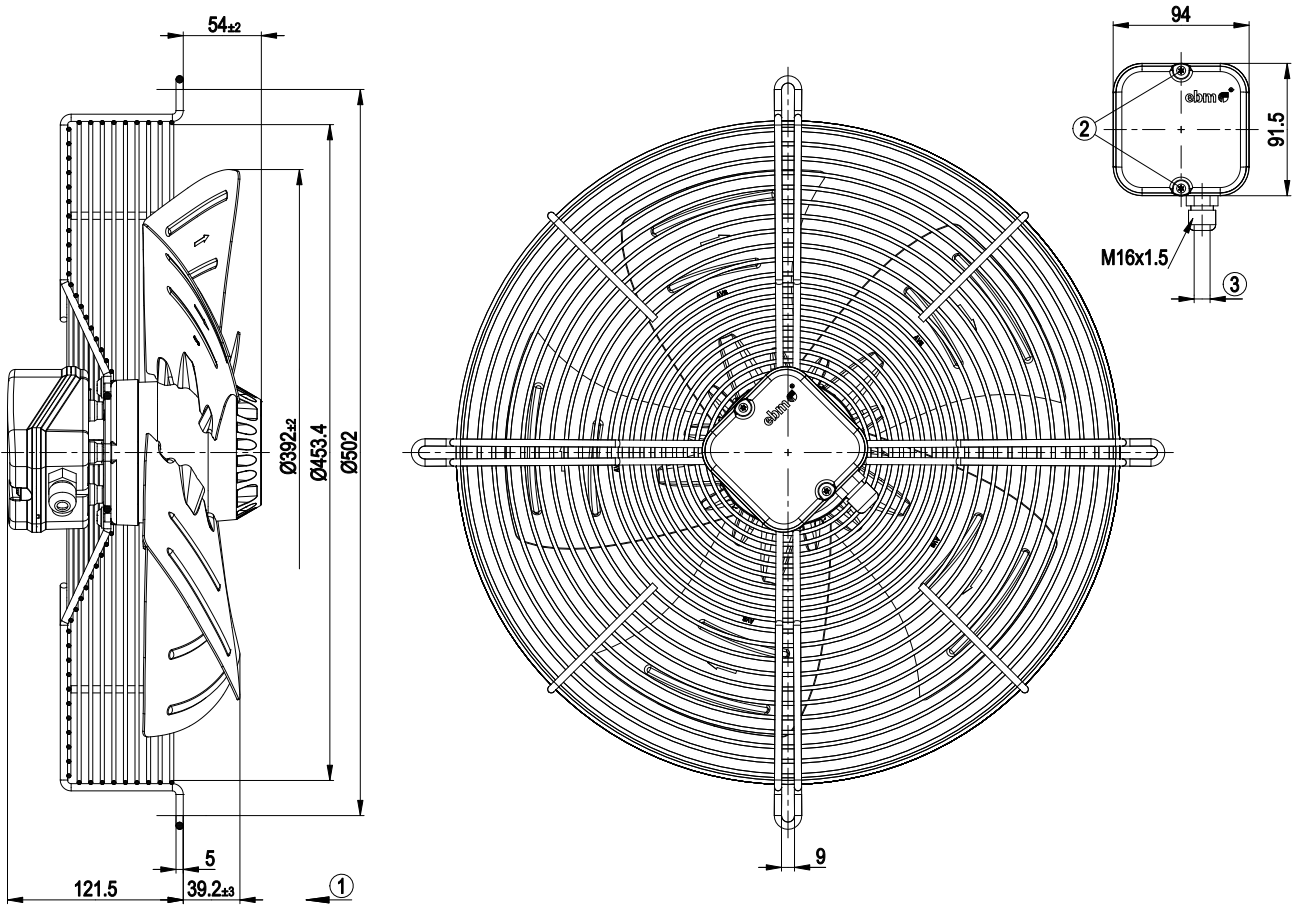

- 1 Direction of air flow "V"
- 2 Tightening torque 0.5±0.1 Nm
- 3 Cable diameter: max. 7.5 mm, tightening torque 1.3±0.2 Nm

## Connection screen

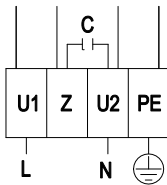

L	= U1 = blue	Z	brown	N	= U2 = black
PE	green/yellow				



# AC axial fan

sickled blades (S series)

with guard grille for short nozzle

## Charts: Air flow 50 Hz

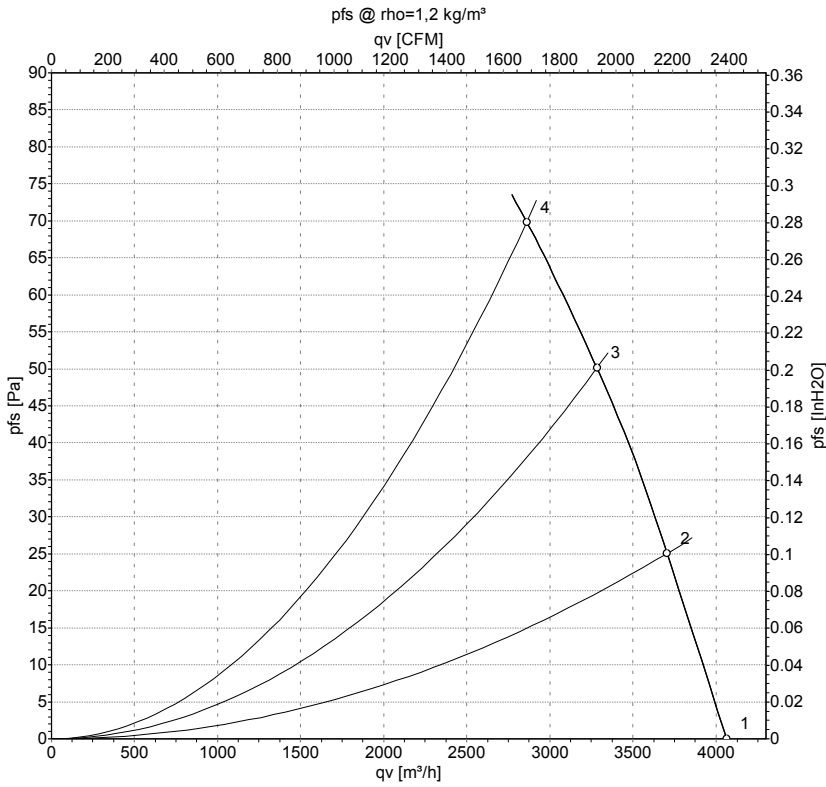

Measurement: LU-33842

Air performance measured as per ISO 5801 Installation category A. For detailed information on the measuring set-up, please contact ebm-papst. Suction-side noise levels: LwA measured as per ISO 13347 / LpA measured with 1m distance to fan axis. The values given are valid under the measuring conditions mentioned above and may vary according to the actual installation situation. With any deviation from the standard set-up, the specific values have to be checked and reviewed with the unit installed.

## Measured values

	U	f	n	P <sub>e</sub>	I	qv	P <sub>fs</sub>
	V	Hz	min <sup>-1</sup>	W	A	m³/h	Pa
1	230	50	1400	150	0.66	4065	0
2	230	50	1385	158	0.69	3705	25
3	230	50	1360	171	0.75	3285	50
4	230	50	1340	184	0.80	2860	70

U = Supply voltage · f = Frequency · n = Speed · P<sub>e</sub> = Power input · I = Current draw · qv = Air flow · P<sub>fs</sub> = Pressure increase

