



Duct Connected -Low/Middle Static Pressure- FDUM

Model No.

FDUM22KXE6F	FDUM71KXE6F
FDUM28KXE6F	FDUM90KXE6F
FDUM36KXE6F	FDUM112KXE6F
FDUM45KXE6F	FDUM140KXE6F
FDUM56KXE6F	FDUM160KXE6F



Filter kit (option)

- UM-FL1EF : for 22~56
- UM-FL2EF : for 71, 90
- UM-FL3EF : for 112, 140, 160



*Filter pressure loss:5pa

Remote control (option)

Wired

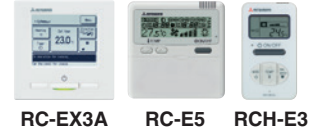

Wireless



RCN-KIT4-E2

Automatic external static pressure (E.S.P.) control

Duct design was simplified.
Using DC motor, the most optimum air flow volume can be achieved by this automatic control.
Indoor unit will recognize external static pressure by itself automatically and keep rated air flow volume.

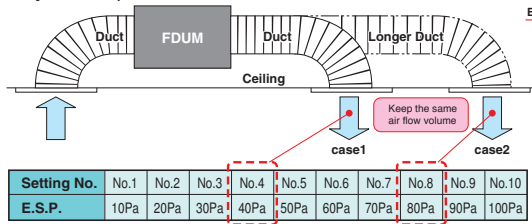

External static pressure (E.S.P.) can be set by E.S.P. button.

Thin design

The height of all FDUM models is only 280mm.

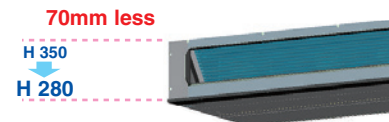

FDUM112/140KXE6F

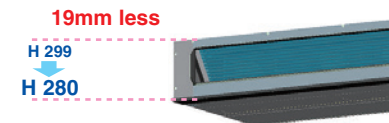

FDUM22-90KXE6F

Improvement of the serviceability

Fan unit (impeller and motor) can be pulled out from the right side or the bottom side of the unit. Maintenance can be available from the right side or the bottom side.

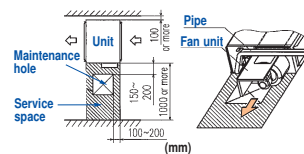

Transparent inspection window

Dirt condition of the bottom of a drain pan can be checked through this transparent inspection window without removing drain pan. (Please refer to P84)

Specifications

Item	Model	FDUM22KXE6F	FDUM28KXE6F	FDUM36KXE6F	FDUM45KXE6F	FDUM56KXE6F	FDUM71KXE6F	FDUM90KXE6F	FDUM112KXE6F	FDUM140KXE6F	FDUM160KXE6F	
Nominal cooling capacity	kW	2.2	2.8	3.6	4.5	5.6	7.1	9.0	11.2	14.0	16.0	
Nominal heating capacity	kW	2.5	3.2	4.0	5.0	6.3	8.0	10.0	12.5	16.0	18.0	
Power source		1 Phase 220-240V, 50Hz										
Power consumption	Cooling	0.10-0.10					0.20-0.20			0.29-0.29	0.33-0.33	0.45-0.45
	Heating	0.10-0.10					0.20-0.20			0.29-0.29	0.33-0.33	0.45-0.45
Sound power level	dB(A)	60					65			—		
Sound pressure level	dB(A)	P-Hi:37 Hi:32 Me:29 Lo:26					P-Hi:38 Hi:33 Me:29 Lo:25			P-Hi:44 Hi:38 Me:36 Lo:30 P-Hi:45 Hi:40 Me:34 Lo:29 P-Hi:47 Hi:40 Me:35 Lo:30		
Exterior dimensions H x W x D	mm	280 x 750 x 635					280 x 950 x 635			280 x 1370 x 740		
Net weight	kg	29					34			54		
Air flow	m ³ /min	P-Hi:13 Hi:10 Me:9 Lo:8					P-Hi:24 Hi:19 Me:15 Lo:10			P-Hi:36 Hi:28 Me:25 Lo:19 P-Hi:39 Hi:32 Me:26 Lo:20 P-Hi:48 Hi:35 Me:28 Lo:22		
Maximum external static pressure	Pa	100										
Outside air intake		Possible										
Air filter		Filter kit:UM-FL1EF/UM-FL2EF/UM-FL3EF(option)										
Remote control(option)		wired:RC-EX3A, RC-E5, RCH-E3 wireless:RCN-KIT4-E2										
Installation data Refrigerant piping size	mm(in)	Liquid line:ø6.35(1/4")			Liquid line:ø6.35(1/4")			Liquid line:ø9.52(3/8")				
		Gas line:ø9.52(3/8")			Gas line:ø12.7(1/2")			Gas line:ø15.88(5/8")				

1. The data are measured under the following conditions(ISO-T1). Cooling: Indoor temp. of 27°CDB, 19°CWB, and outdoor temp. of 35°CDB. Heating: Indoor temp. of 20°CDB, and outdoor temp. of 7°CDB, 6°CWB. External static pressure of indoor unit is 35Pa(22/28/36/45/56/71/90), 60Pa(112/140/160).
2. Sound pressure level indicates the value in an anechoic chamber. During operation these values are somewhat higher due to ambient conditions.

Dimensions

All measurements in mm.

FDUM22KXE6F, 28KXE6F, 36KXE6F, 45KXE6F, 56KXE6F

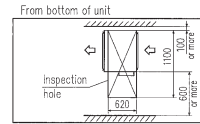
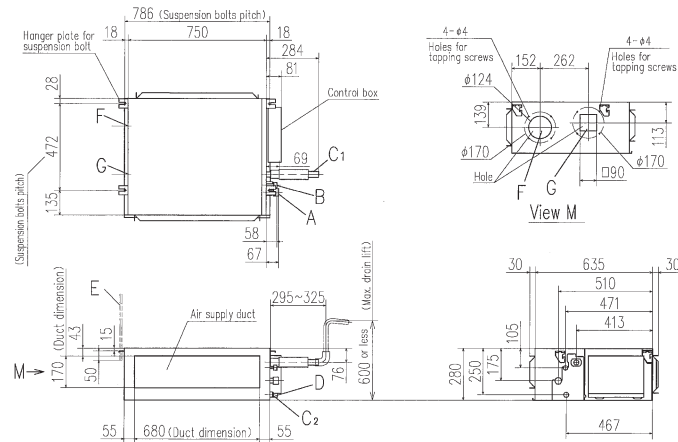

Symbol	Model	Content
A	Gas piping	22.28 (Floare) 36.45.56 (Floare)
B	Liquid piping	ø9.52 (3/8") (Floare) ø12.7 (1/2") (Floare)
C1	Drain piping	VP25 (O.D.32)
C2	Drain piping (Gravily drainage)	VP20
D	Hole for wiring	
E	Suspension bolts	(M10)
F	Outside air opening for ducting	(Knock out)
G	Air outlet opening for ducting	(Knock out)
H	Inspection hole	(450X450)

Note: The model name label is attached on the lid of the control box.

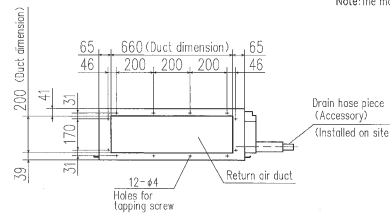

FDUM71KXE6F, 90KXE6F

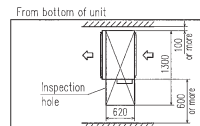
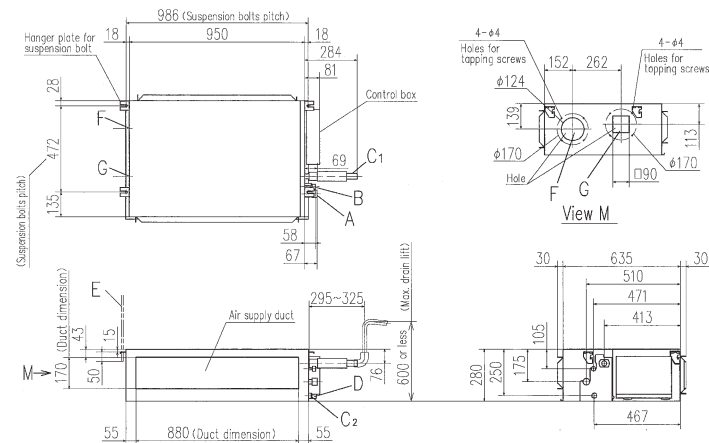

Symbol	Model	Content
A	Gas piping	ø15.88 (5/8") (Floare)
B	Liquid piping	ø9.52 (3/8") (Floare)
C1	Drain piping	VP25 (O.D.32)
C2	Drain piping (Gravily drainage)	VP20
D	Hole for wiring	
E	Suspension bolts	(M10)
F	Outside air opening for ducting	(Knock out)
G	Air outlet opening for ducting	(Knock out)
H	Inspection hole	(450X450)

Note: The model name label is attached on the lid of the control box.

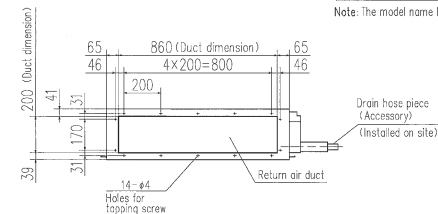

FDUM112KXE6F, 140KXE6F, 160KXE6F

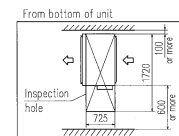
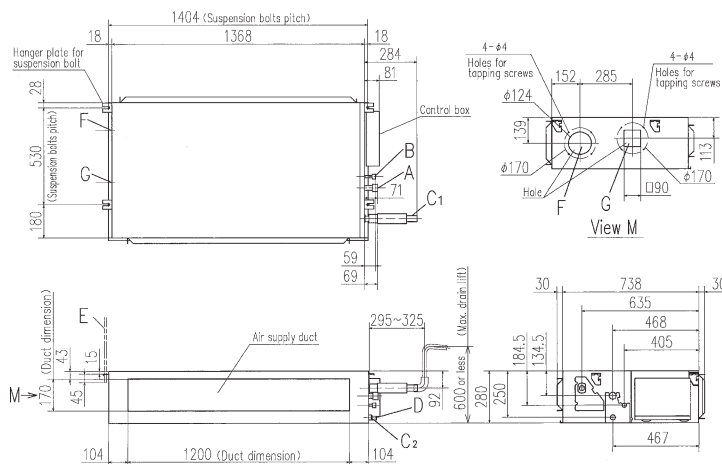

Symbol	Model	Content
A	Gas piping	ø15.88 (5/8") (Floare)
B	Liquid piping	ø9.52 (3/8") (Floare)
C1	Drain piping	VP25 (O.D.32)
C2	Drain piping (Gravily drainage)	VP20
D	Hole for wiring	
E	Suspension bolts	(M10)
F	Outside air opening for ducting	(Knock out)
G	Air outlet opening for ducting	(Knock out)
H	Inspection hole	(450X450)

Note: The model name label is attached on the lid of the control box.

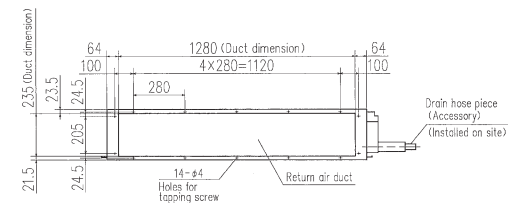

Round duct adapter

In case of requirements of round duct adapter, please refer to P93.

Company URL **AIRZONE**
<http://www.airzone.es>