



Ordering Key

G	D	H	200	48	Z	D1
1	2	3	4	5	6	7

- 1: Greegoo brand;
- 2: Switch type: S - small size (1-5A), D - single phase, T - three phase;
- 3: Output method, blank - triac output, H - SCR output;
- 4: Rated working current (A);
- 5: Rated working voltage (V) (24:240V,44:440V,48:480V);
- 6: Control method Z - Zero, R - Random;
- 7: Control voltage D: 3-8V, D1 - 4-16VDC, D3 - 3-32VDC, A2 - 90-250VAC.

GD 10 to 40 Amps AC SSR

Series GD Solid State Relays are AC relays, Triac Output. The triac version of the zero switching relay is an inexpensive solution for resistive loads. The zero switching relay switches on when the AC sine voltage just crosses zero, and switches off when the current crosses zero.

- Rated operational current 10 to 40 Amps.
- Rated operational voltage 240V or 440 V
- Input Voltage Range 4 to 16 Vdc, 3 to 32 Vdc or 90 to 250 Vac.
- 4000 Vrms Optical Isolation.(input/output)
- Both "Zero Voltage" & phase controllable "Random Switching" versions.
- LED-indication for control input.

Type Selection

- Mounting type
D: AC Single phase Solid State Relay
- Rated operational current
10: 10Amp, 15: 15Amp, 25: 25Amp, 40: 40Amp
- Rated operational voltage
24: 240VAC, 44: 440VAC.
- Switched mode
Z: Zero Voltage,R: Random Switching.
- Input Control voltage
D1: DC 4to16V, D3: DC 3to32V, A2: 90to250V.

Selection guide

Voltage	Control voltage	Rated operational current			
		10 Amp	15 Amp	25 Amp	40 Amp
240 VAC "Z"	4 to 16 Vdc	GD1024ZD1	GD1524ZD1	GD2524ZD1	GD4024ZD1
240 VAC "R"	4 to 16 Vdc	GD1024RD1	GD1524RD1	GD2524RD1	GD4024RD1
240 VAC "Z"	3 to 32 Vdc	GD1024ZD3	GD1524ZD3	GD2524ZD3	GD4024ZD3
240 VAC "R"	3 to 32 Vdc	GD1024RD3	GD1524RD3	GD2524RD3	GD4024RD3
240 VAC "Z"	90 to 250Vac	GD1024ZA2	GD4024ZA2	GD4024ZA2	GD4024ZA2
240 VAC "R"	90 to 250Vac	GD1024RA2	GD4024RA2	GD4024RA2	GD4024RA2
440 VAC "Z"	4 to 16 Vdc	GD1044ZD1	GD1544ZD1	GD2544ZD1	GD4044ZD1
440 VAC "R"	4 to 16 Vdc	GD1044RD1	GD1544RD1	GD2544RD1	GD4044RD1
440 VAC "Z"	3 to 32 Vdc	GD1044ZD3	GD1544ZD3	GD2544ZD3	GD4044ZD3
440 VAC "R"	3 to 32 Vdc	GD1044RD3	GD1544RD3	GD2544RD3	GD4044RD3
440 VAC "Z"	90 to 250Vac	GD1044ZA2	GD1044ZA2	GD2544ZA2	GD4044ZA2
440 VAC "R"	90 to 250Vac	GD1044RA2	GD1044RA2	GD2544RA2	GD1044RA2

Dimension

GD 10 to 40 Case A

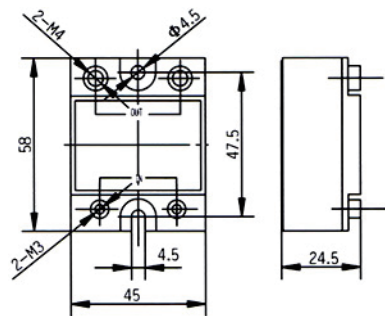

GD 10 to 40 Case B

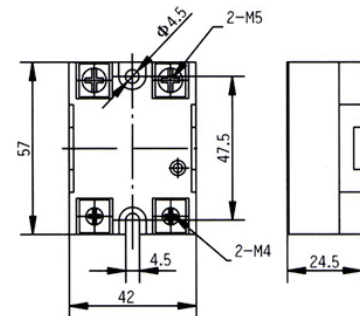

Specifications

PARAMETER-LIST	Units	Specification Limits		
Input Parameter ①	D1	D3	A2	
Control Voltage Range	4 to 16Vdc	3 to 32Vdc	90 to 250Vac	
Input Current (Max.)	7/20 mAdc @=5V/12V	13/16 mAdc @=5V/12	30 MAac @=220V	
Must Turn On Voltage	4Vdc	3 Vdc	90Vac	
Must Turn Off Voltage	1Vdc	1 Vdc	10Vac	

Output Parameter ②	Units	Specification Limits			
Model No. GD		10	15	25	40
Load Current Range	Arms	0.05 to 10	0.05 to 15	0.05 to 25	0.05 to 40
Surge Current, 20 mSec (Max.)	Arms	85	115	230	400
Load Voltage Range (240V)	Vrms	24 to 280			
TRIAC Over voltage(240V)	Vpk	≥600			
Load Voltage Range (440V)	Vrms	44 to 440			
TRIAC Over voltage(440V)	Vpk	≥800			
Thermal Resistance, (Rthjc)	°C/w	2.5	2.5	1.3	1.1
Frequency Range	Hz	47 to 63			
Off State dv/dt (Min)	V/μsec	200			
Off State Leakage Current (Max.)	mArms	≤8			
On State Voltage Drop (Max.)	Vrms	1.6			
Turn On Time (Max.) "Z"	Cycle	1/2			
Turn On Time (Max.) "R"	mSec	1			
Turn Off Time (Max.)	Cycle	1/2			
Turn Off Time(Max.)"A2"	mSec	40			

Coupling Specifications

Dielectric (Input/Output)	Vrms	2500
Dielectric (Input-Output/Base)	Vrms	2500
Capacitance	pf	10

General Specifications

Ambient temperature range: operating or Storage -30°C to +80°C

Weight(typical.): **Case A** Aluminum Base plate: 99g; Copper Base plate: 145g

Case B Aluminum Base plate: 81g; Copper Base plate: 120g

Base plate: Aluminum or Copper, nickel-plated

Case Color: Black

Reverse Voltage (Max.)	32 Vdc	32 Vdc	/
LED Display	Optional	Optional	Optional