

serie 30

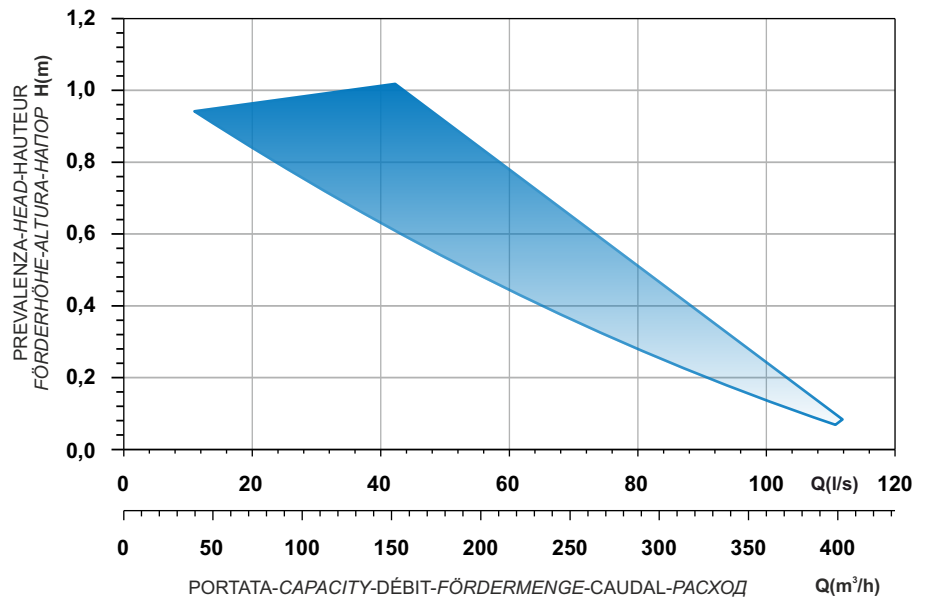

Curva caratteristica - Performance curve - Courbe caractéristique
Kennlinie - Curva característica - Характеристическая кривая



Code	Type	Motor type	Power supply	Rotation speed r.p.m.	Discharge	Weight Kg
Ghisa - Cast Iron - Fonte - Grauguss - Hierro fundido - Чугун EN-GJL-250						
9004874	GM30A609T1-4N2KA0	M609T-2,7-400/50NN-IE3	3ph 400V-50Hz	931	DN 300	60
9008212	GM30B610R1-4N2KA2	M610T-4-400/50YY-IE3	3ph 400/690V-50Hz	931	DN 300	62
Acciaio inossidabile - Stainless steel - Acier inoxydable - Edelstahl - Acero inoxidable - Нержавеющая сталь AISI 316L						
9006473	XM30A609T1-6N2LA4	M609T-2,7-400/50NN-IE3	3ph 400V-50Hz	931	DN 300	66
9005891	XM30B610R1-6N2LA5	M610T-4-400/50YY-IE3	3ph 400/690V-50Hz	931	DN 300	70

Dimensioni - Dimensions - Dimensions - Abmessungen - Dimensiones - Габариты (mm)

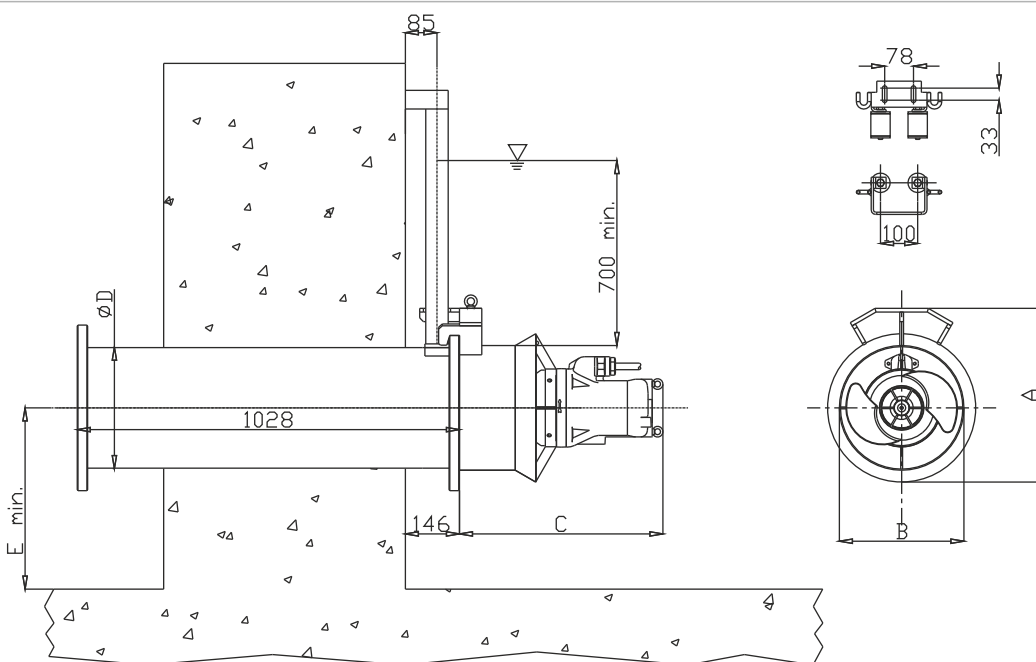

▽ LIVELLO MINIMO DI SOMMERGIBILITÀ
MINIMUM SUBMERSIBLE LEVEL
NIVEAU MINIMUM D'IMMERSION
MINDESTWASSERSTAND
NIVEL SUMERGIBLE MÍNIMO
МИНИМАЛЬНАЯ ГЛУБИНА ПОГРУЖЕНИЯ

N	Type	A(mm)	B(mm)	C(mm)	D(mm)	E(mm)
1	GM/XM30A609T1	467	335	547	326	300
2	GM/XM30B610R1	467	335	616	326	300