

SUBMERSIBLE MIXERS

Miscelatori sommergibili
Submersible mixers
Agitateurs submersibles
Tauchrührwerke
Agitador sumergible
Погружные смесители

3ph 400V 50Hz

Code	Type	Absorbed power P1 kW	Propeller diameter mm	Thrust N	Weight Kg	Motor type	Rotation r.p.m.	Motor Rated power kW	Max. I A
6001408	GM17A471T1-4V2KA0	0,6	176	120	20	M471T-0,7-400/50NN-IE3	1352	0,7	1,5
6001412	GM18B471T1-4V2KA0	1,2	191	220	30	M471T-1,4-400/50NN-IE3	1382	1,4	2,7
6001431	GM18B471T1-4T6KA0	1,2	191	220	30	M471T-1,4-400/50NN-IE3	1382	1,4	2,7
6007801	GM19B409T1-4T6KA0	1,7	197	275	40	M409T-2,3-400/50NN-IE3	1382	2,3	4,4
6001521	GM30A609T1-4T6KA0	2	300	300	44	M609T-2,3-400/50NN-IE3	931	2,3	5
6001522	GM30B610R1-4T6KA2	2,5	300	320	57	M610T-3,2-400/50YY-IE3	931	3,2	6,9
6009060	GM37B810R1-4T6KA2	1,6	370	385	58	M810T-2-400/50YY-IE	696	2	5,1
6001519	GM40B813R1-4T6KA2	2,2	400	420	114	M813T-2,5-400/50YY-IE	696	2,5	6,2
6002688	GM40B813R2-4T6KA2	3,3	400	650	114	M813T-3,7-400/50YY-IE	701	3,7	8,9
6008654	GM40B813R3-4T6SA2	4,3	400	780	125	M813T-5,2-400/50YY-IE	706	5,2	12,1
6002689	GM60B1216R1-4T1KA2	5,1	600	1040	240	M1216T-7,5-400/50YY-IE	461	7,5	18,6
6002594	GM60B1216R2-4T1KA2	7	600	1500	240	M1216T-7,5-400/50YY-IE	461	7,5	18,6
6004979	GM60B1216R3-4T1KA2	9,7	600	1850	240	M1216T-12-400/50YY-IE	475	12	28,4
6002161	GM60B1016R3-4C1KA2	9,8	600	2275	275	M1016T-12-400/50YY-IE	549	12	26,5
6001402	XM17A472T1-6V2LA4	0,6	176	120	20	M472T-0,7-400/50NN-IE3	1352	0,7	1,5
6001980	XM18B471T1-6T6LA4	1,2	191	220	30	M471T-1,4-400/50NN-IE3	1382	1,4	2,7
6007802	XM19B409T1-6T6LA4	1,7	197	275	46	M409T-2,3-400/50NN-IE3	1382	2,3	4,4
6005353	XM30A609T1-6T6LA4	2	300	300	50	M609T-2,3-400/50NN-IE3	931	2,3	5
6005504	XM30B610R1-6T6LA5	2,5	300	320	65	M610T-3,2-400/50YY-IE3	931	3,2	6,9
6001202	XM37B810R1-6T6LA5	1,6	370	385	68	M810T-2-400/50YY-IE	696	2	5,1
6007884	XM40B813R1-6T6LA5	2,2	400	420	114	M813T-2,5-400/50YY-IE	696	2,5	6,2
6001520	XM40B813R2-6T6LA5	3,3	400	650	114	M813T-3,7-400/50YY-IE	701	3,7	8,9
6008649	XM40B813R3-6T6SA5	4,3	400	780	125	M813T-5,2-400/50YY-IE	706	5,2	12,1
6001478	XM60B1216R1-6T1LA5	5,1	600	1040	245	M1216T-7,5-400/50YY-IE	461	7,5	18,6
6001480	XM60B1216R2-6T1LA5	7	600	1500	245	M1216T-7,5-400/50YY-IE	461	7,5	18,6
6001518	XM60B1216R3-6T1LA5	9,7	600	1850	245	M1216T-12-400/50YY-IE	475	12	28,4
6003408	XM60B1016R3-6C1LA5	9,8	600	2275	280	M1016T-12-400/50YY-IE	549	12	26,5
6001805	GR12B410R3-4T1AA2	2,7	1200	1350	115	M410T-3,5-400/50YY-IE3	1392	3,5	6,8

Prestazioni rilevate secondo ISO21630:2007 - Operating data obtained in accordance to ISO21630:2007 - Performances relevées selon norme ISO21630:2007 - Leistungsdaten erhoben gemäß der norm ISO21630:2007 - Производительность соответствующая согласно ISO21630:2007

XM17

Ø 176 mm



Miscelatori sommersibili
Agitateurs submersibles
Agitador sumergible



Submersible mixers
Tauchrührwerke
Погружные смесители

Code	Type	Absorbed power P1 kW	Propeller diameter mm	Thrust N	Weight Kg	Motor Rated		
						RPM	Power kW	Current A
6001402	XM17A472T1-6V2LA4	0,6	176	120	20	1352	0,7	1,5

Materiali - Materials - Matériaux - Werkstoffe - Materiales - Материалы

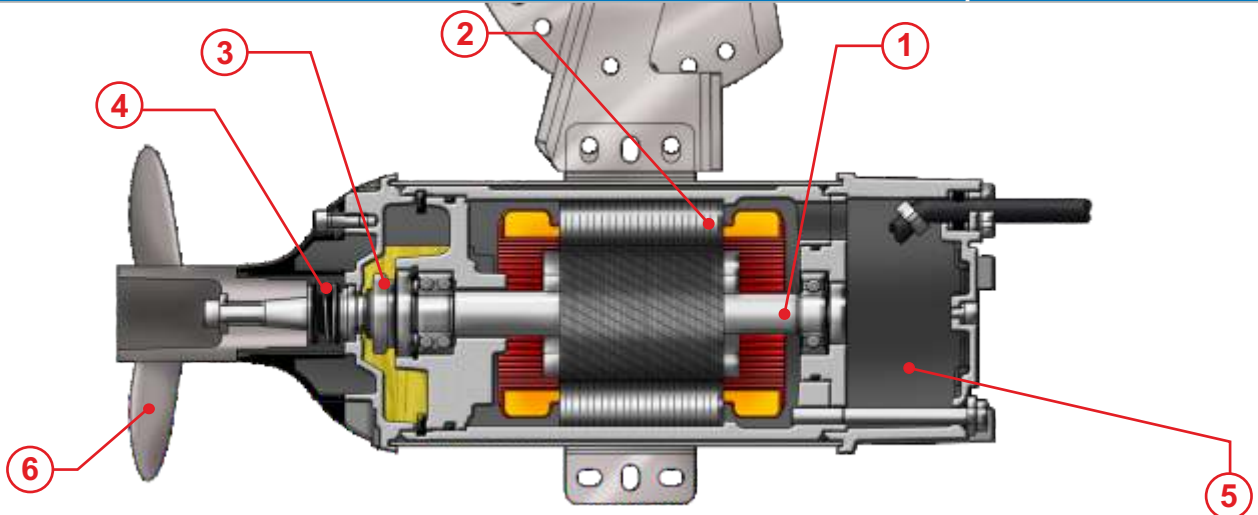

- 1) Alberi realizzati in acciaio inossidabile AISI 316L.
- 2) Motore asincrono trifase 4 poli, classe d'isolamento H(180°C).
- 3) Tenuta superiore: ceramica/grafite.
- 4) Tenuta inferiore: carburo di Silicio/carburo di silicio/viton.
- 5) Fusioni: Acciaio inox AISI316L
- 6) Elica: Acciaio inossidabile AISI 316L



- 1) Les arbres sont réalisés en acier inoxydable AISI 316L.
- 2) Moteur asynchrone triphasé 4 pôles, classe d'isolation H(180°C).
- 3) Garniture supérieure : mécanique, céramique/carbone.
- 4) Garniture inférieure: mécanique, carbure de silicium/carbure de silicium/viton.
- 5) Moulures: Acier inoxydable AISI316L
- 6) Hélice: Acier inoxydable AISI316L



- 1) Ejes realizados en acero inoxidable AISI316L.
- 2) Motor asincrónico trifásico 4 polos, aislamiento H(180°C).
- 3) Sellado/precintado superior: grafito de cerámica.
- 4) Sellado/precintado inferior: carburo y silicio/carburo y silicio/viton.
- 5) Aleaciones: Acero inoxidable AISI316L
- 6) Hélice: Acero inoxidable AISI316L



- 1) Shafts realized in stainless steel AISI 316L.
- 2) Motor asynchronous threephase 4 poles, insulation class H(180°C).
- 3) Upper seal: ceramic/graphite.
- 4) Lower seal: silicon carbide/silicon carbide/viton.
- 5) Housing: Stainless steel AISI316L
- 6) Propeller: Stainless steel AISI316L



- 1) Welle aus Edelstahl AISI 316L.
- 2) Motor Asynchronmotor dreiphasig 4-polig, Isolationsklasse H(180°C).
- 3) Obere Dichtung: Gleitringdichtung Kohle/Keramik.
- 4) Untere Dichtung: Gleitringdichtung Siliziumkarbid / Siliziumkarbid / Viton.
- 5) Motorgehäuse: Edelstahl AISI316L
- 6) Propeller: Edelstahl AISI316L



- 1) Валы реализованы из нержавеющей стали AISI 316L.
- 2) Асинхронный двигатель трёхфазный 4 полюса, класс изоляции H (180°C).
- 3) Верхнее уплотнение: керамика/графит
- 4) Нижнее уплотнение: Карбид кремния / Карбид кремния/ Витон
- 5) Литья: Нержавеющая сталь AISI 316L
- 6) Пропеллер: нержавеющая сталь AISI 316L

Dimensioni - Dimensions - Dimensions - Abmessungen - Dimensiones - Габариты

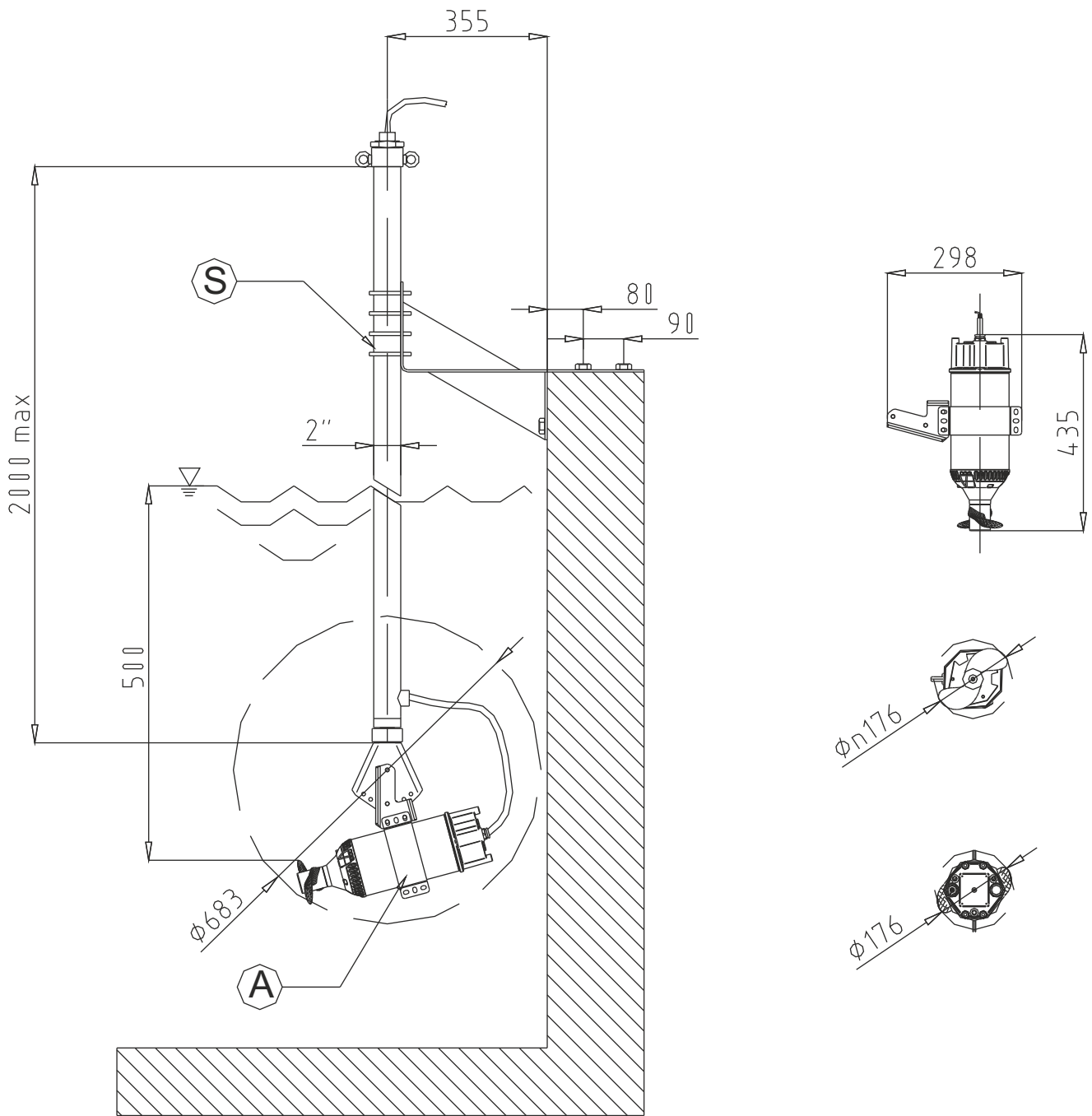

▽ LIVELLO MINIMO DI SOMMERSIBILITÀ
 MINIMUM SUBMERSIBLE LEVEL
 NIVEAU MINIMUM D'IMMERSION
 MINDESTWASSERSTAND
 NIVEL SUMERGIBLE MÍNIMO
 МИНИМАЛЬНАЯ ГЛУБИНА ПОГРУЖЕНИЯ

Pos	Code	Description	Material
A	6001402	Miscelatore sommergibile Submersible mixer Agitateur submersible Tauchrührwerk Mezcladores sumergibles Погружной смеситель	Acciaio inox AISI316 Stainless steel AISI316 Acier inoxydable AISI316 Edelstahl AISI 316 Acero inoxidable AISI316 Нержавеющая сталь AISI 316
S	70.SSM050...	Struttura sostegno Lifting system Système de soulèvement Hebevorrichtung Estructura de sostén Структура поддержки	Acciaio zincato - AISI304/316 Galvanized Steel - AISI304/316 Acier galvanisé - AISI304/316 Stahl verzinkt - AISI304/316 Acero galvanizado - AISI304/316 Оцинков.сталь AISI304/316

