



 Ghisa EN-GJL-250
 Fonte EN-GJL-250
 Hierro fundido EN-GJL-250

 Cast Iron EN-GJL-250
 Grauguss EN-GJL-250
 Чугун EN-GJL-250

Curva caratteristica - Performance curve - Courbe caractéristique
 Kennlinie - Curva característica - Характеристическая кривая

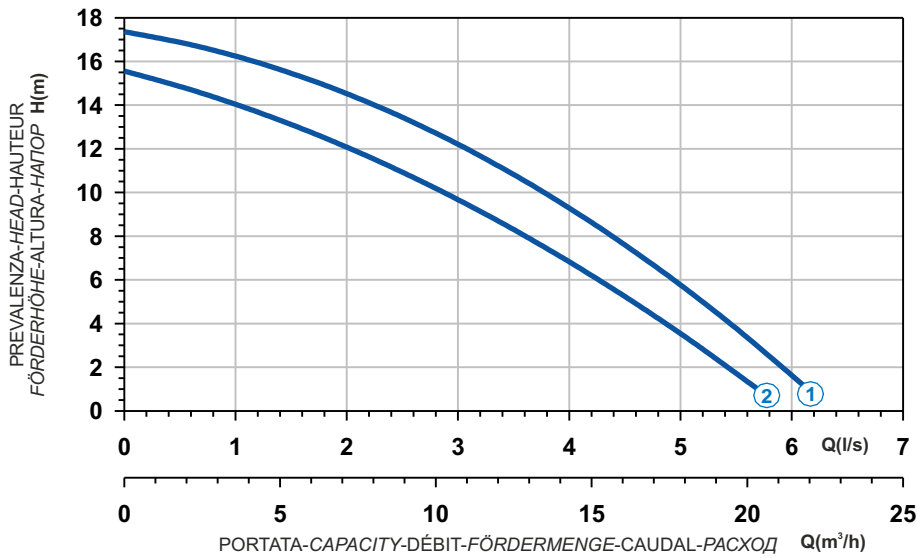

Curve N°	Code	Type	MOTOR			ATEX code 
			Rated power P2 (kW)	Rated current I (A)	Starting current Is (A)	
1	7000951	G272T3D1-J6AA0	1,4	2,7	13,2	-
2	7009017	G272T3D2-J6AA0	1,1	2,4	11,8	-

Power supply	3ph 400V-50Hz
R.P.M.	2850
Free passage (mm)	6
Discharge (mm)	DN 40
Max Weight (Kg)	31

Dimensioni - Dimensions - Dimensions - Abmessungen - Dimensiones - Габариты (mm)

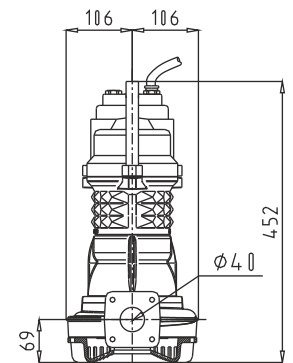
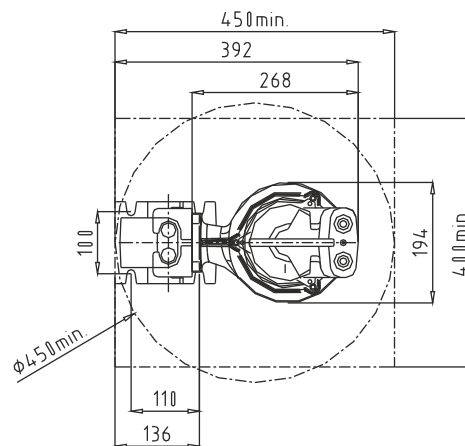
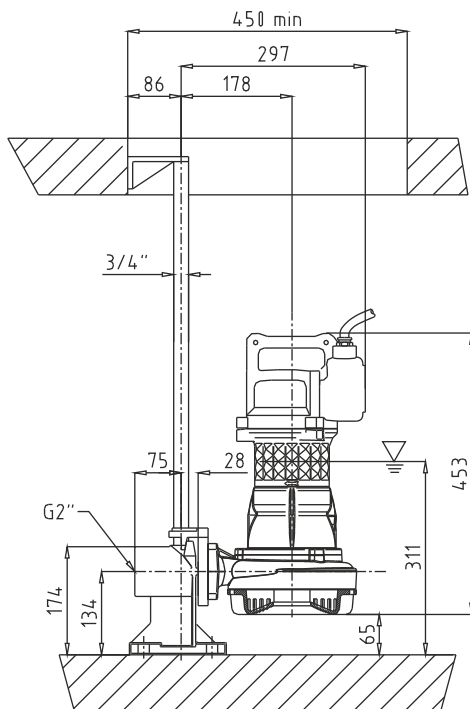

▽ LIVELLO MINIMO DI SOMMERGIBILITÀ
 MINIMUM SUBMERSIBLE LEVEL
 NIVEAU MINIMUM D'IMMERSION
 MINDESTWASSERSTAND
 NIVEL SUMERGIBLE MÍNIMO
 МИНИМАЛЬНАЯ ГЛУБИНА ПОГРУЖЕНИЯ