





 Ghisa EN-GJL-250  
 Fonte EN-GJL-250  
 Hierro fundido EN-GJL-250

 Cast Iron EN-GJL-250  
 Grauguss EN-GJL-250  
 Чугун EN-GJL-250

**Curva caratteristica - Performance curve - Courbe caractéristique**  
**Kennlinie - Curva característica - Характеристическая кривая**

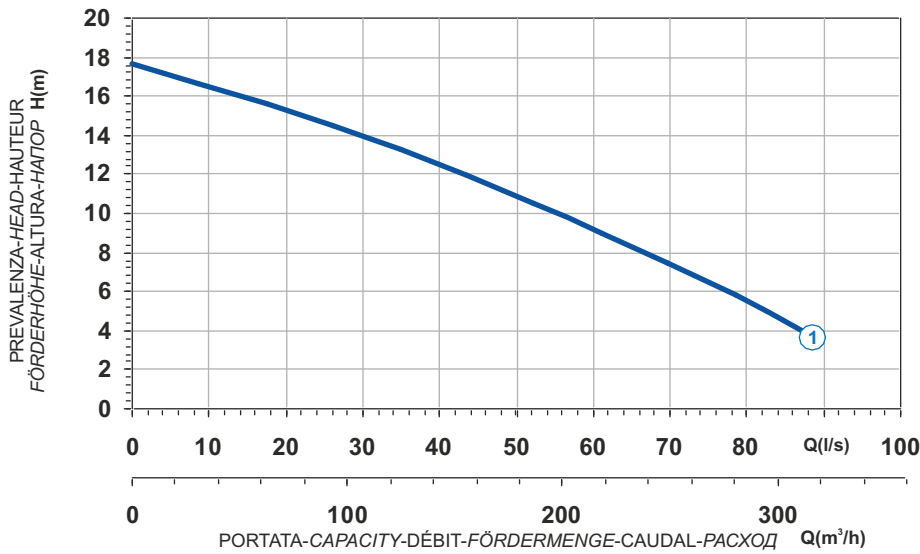

J

Curve N°	Code	Type	MOTOR			ATEX code 
			Rated power P2 (kW)	Rated current I (A)	Starting current Is (A)	
1	7009112	G413R2J5-S60AA2	11,6	21,6	127	7007334

Power supply	3ph 400/690V 50Hz
R.P.M.	1450
Free passage (mm)	60
Discharge (mm)	DN 150
Max Weight (Kg)	255

**Dimensioni - Dimensions - Dimensions - Abmessungen - Dimensiones - Габариты (mm)**

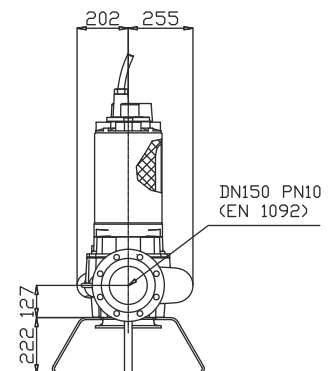
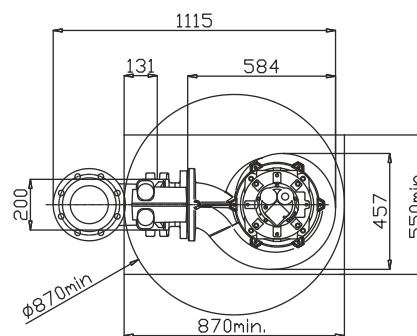
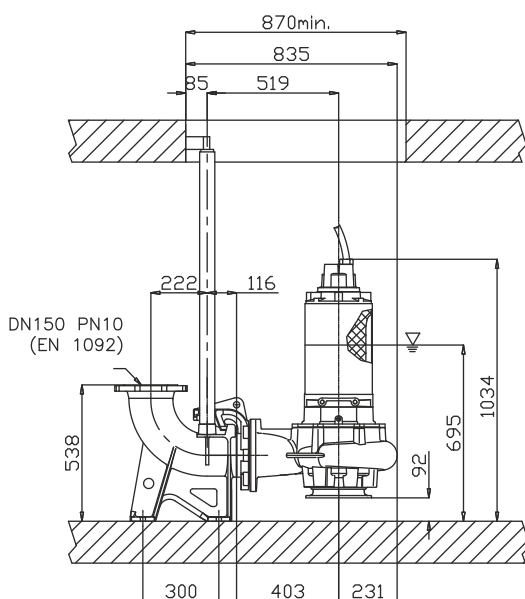

▽ LIVELLO MINIMO DI SOMMERGIBILITÀ  
 MINIMUM SUBMERSIBLE LEVEL  
 NIVEAU MINIMUM D'IMMERSION  
 MINDESTWASSERSTAND  
 NIVEL SUMERGIBLE MÍNIMO  
 МИНИМАЛЬНАЯ ГЛУБИНА ПОГРУЖЕНИЯ