

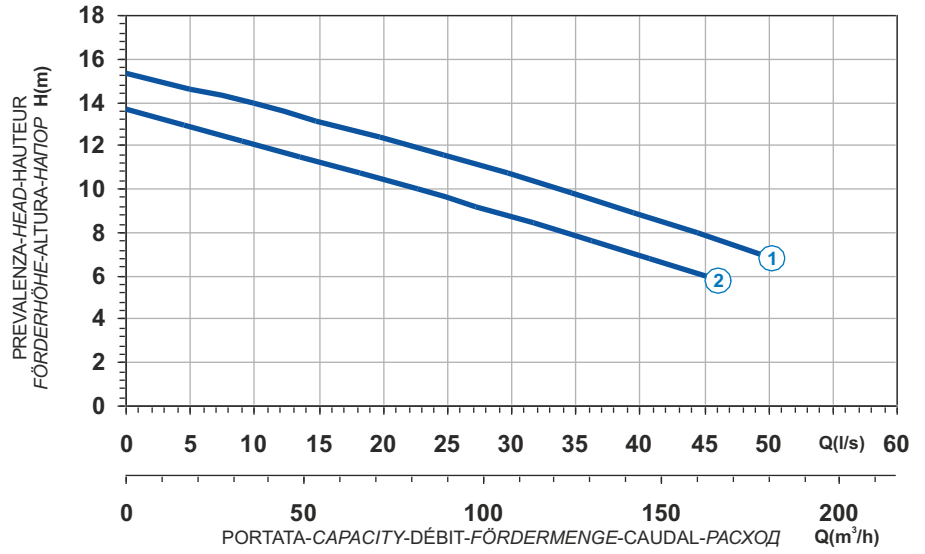

Ghisa EN-GJL-250
 Fonte EN-GJL-250
 Hierro fundido EN-GJL-250

Cast Iron EN-GJL-250
 Grauguss EN-GJL-250
 Чугун EN-GJL-250

Curva caratteristica - Performance curve - Courbe caractéristique
 Kennlinie - Curva característica - Характеристическая кривая



Power supply	3ph 400/690V 50Hz
R.P.M.	1450
Free passage (mm)	60
Discharge (mm)	DN 100
Max Weight (Kg)	190

Curve N°	Code	Type	MOTOR			ATEX code
			Rated power P2 (kW)	Rated current I (A)	Starting current Is (A)	
1	7000357	G411R2J2-P60AA2	7,1	13,5	79,7	7005934
2	7005870	G411R2J3-P60AA2	7,1	13,5	79,7	7005938

Dimensioni - Dimensions - Dimensions - Abmessungen - Dimensiones - Габариты (mm)

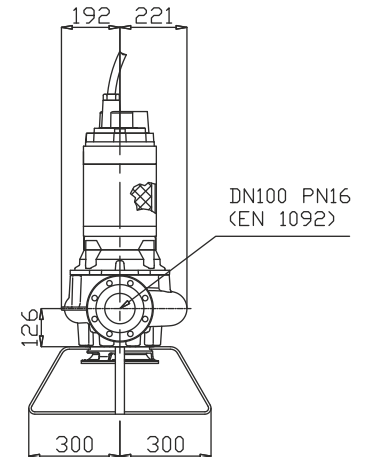
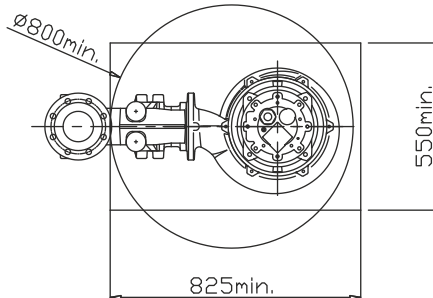
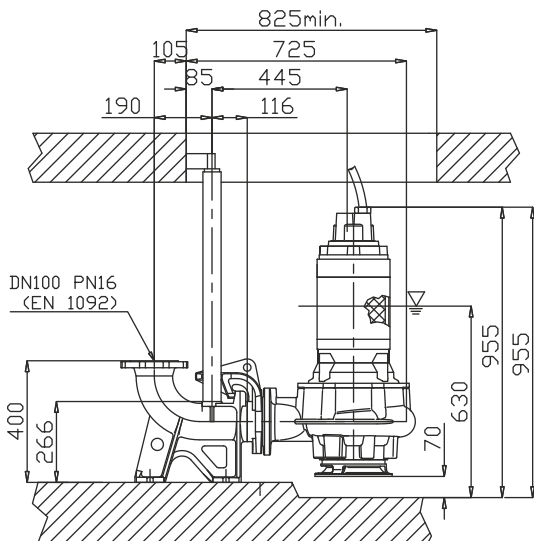

▽ LIVELLO MINIMO DI SOMMERSIBILITÀ
 MINIMUM SUBMERSIBLE LEVEL
 NIVEAU MINIMUM D'IMMERSION
 MINDESTWASSERSTAND
 NIVEL SUMERGIBLE MÍNIMO
 МИНИМАЛЬНАЯ ГЛУБИНА ПОГРУЖЕНИЯ