

# AC axial fan

straight blades (A series), single inlet  
with guard grille for full nozzle



## Nominal data

<b>Type</b>	S4D350-BA06-08				
<b>Motor</b>	M4D068-EC				
Phase		3~	3~	3~	3~
Nominal voltage	VAC	230	230	400	400
Connection		$\Delta$	$\Delta$	Y	Y
Frequency	Hz	50	60	50	60
Type of data definition		fa	fa	fa	fa
Valid for approval / standard		-	-	-	-
Speed	min <sup>-1</sup>	1420	1620	1420	1620
Power input	W	145	190	145	190
Current draw	A	0.68	0.62	0.39	0.36
Max. back pressure	Pa	150	150	150	150
Min. ambient temperature	°C	-25	-25	-25	-25
Max. ambient temperature	°C	50	50	50	50

ml = Max. load · me = Max. efficiency · fa = Running at free air · cs = Customer specs · cu = Customer unit  
Subject to alterations

## Data according to ErP directive

Installation category	A	Overall efficiency $\eta_{es}$	%	Actual 28.5	Request 2013 24.5	Request 2015 28.5
Efficiency category	Static	Efficiency grade N		40	36	40
Variable speed drive	No	Power input $P_e$	kW	0.15		
Specific ratio*	1.00	Air flow $q_v$	m <sup>3</sup> /h	2015		
		Pressure increase $p_{fs}$	Pa	75		
		Speed n	min <sup>-1</sup>	1390		

\* Specific ratio =  $1 + p_b / 100\,000\text{ Pa}$

Data definition with optimum efficiency. LU-64797  
The ErP data is determined using a motor-impeller combination in a standardised measurement configuration.



# AC axial fan

straight blades (A series), single inlet  
with guard grille for full nozzle

## Technical features

<b>Mass</b>	4.2 kg
<b>Size</b>	350 mm
<b>Surface of rotor</b>	Coated in black
<b>Material of terminal box</b>	ABS plastic
<b>Material of blades</b>	Sheet steel, coated in black
<b>Material of guard grille</b>	Steel, coated in black plastic (RAL9005)
<b>Number of blades</b>	5
<b>Direction of air flow</b>	"A"
<b>Direction of rotation</b>	Clockwise, seen on rotor
<b>Type of protection</b>	IP 44; Depending on installation and position as per EN 60034-5
<b>Insulation class</b>	"B"
<b>Humidity class</b>	F2-2
<b>Max. permissible ambient motor temp. (transp./ storage)</b>	+ 80 °C
<b>Min. permissible ambient motor temp. (transp./storage)</b>	- 40 °C
<b>Mounting position</b>	Shaft horizontal or rotor on bottom; rotor on top on request
<b>Condensate discharge holes</b>	Rotor-side
<b>Operation mode</b>	S1
<b>Motor bearing</b>	Ball bearing
<b>Touch current acc. IEC 60990 (measuring network Fig. 4, TN system)</b>	< 0.75 mA
<b>Electrical leads</b>	Via terminal box
<b>Cable exit</b>	Axial
<b>Protection class</b>	I (if protective earth is connected by customer)
<b>Product conforming to standard</b>	EN 60335-1, motor does not have factory-installed overheating protection
<b>Approval</b>	CCC



## AC axial fan

straight blades (A series), single inlet  
with guard grille for full nozzle

## Product drawing

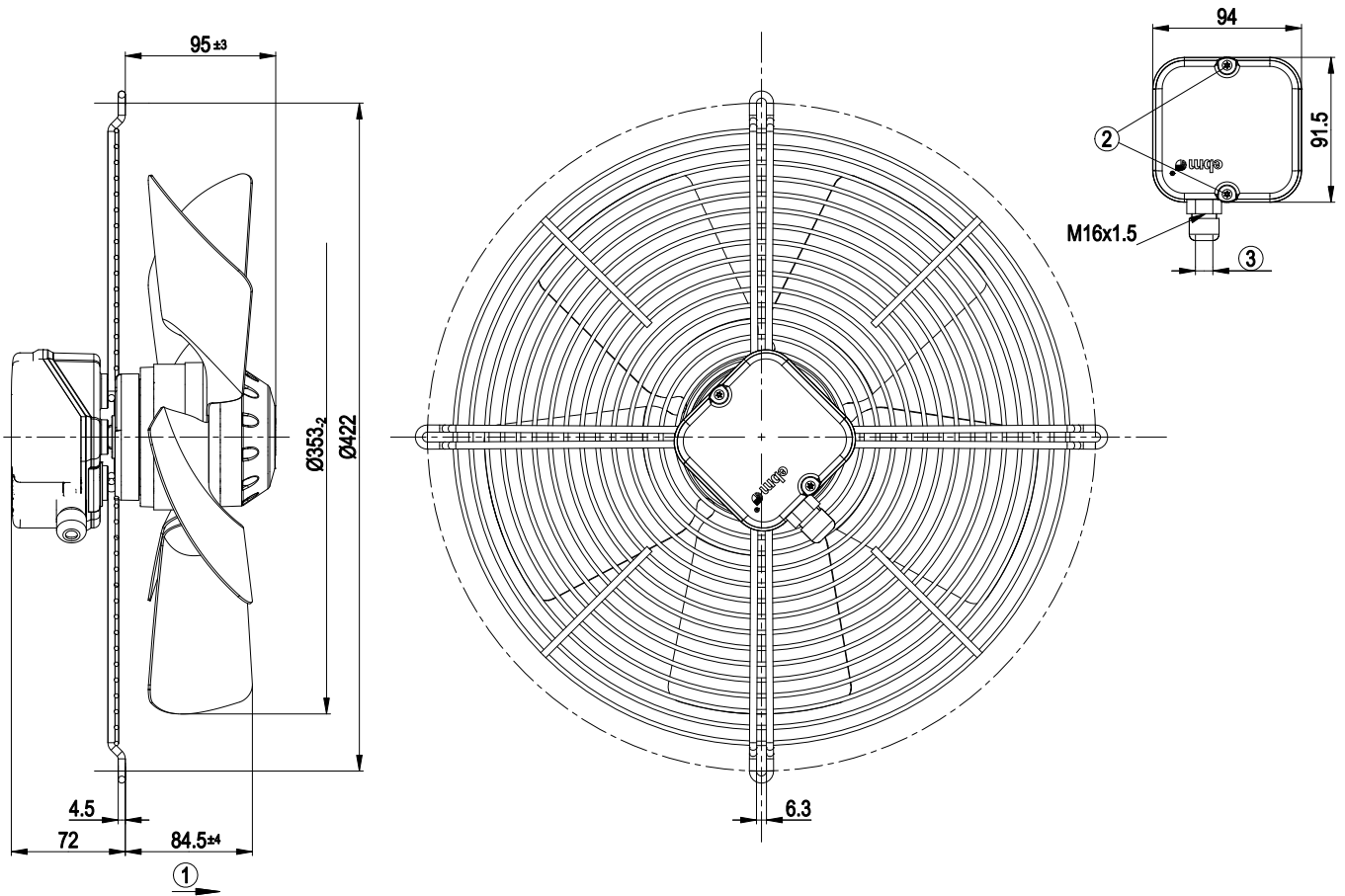

1	Direction of air flow "A"
2	Tightening torque $0.5 \pm 0.1$ Nm
3	Cable diameter max. $7.5$ mm, tightening torque $1.3 \pm 0.2$ Nm

# AC axial fan

straight blades (A series), single inlet  
with guard grille for full nozzle

## Connection screen

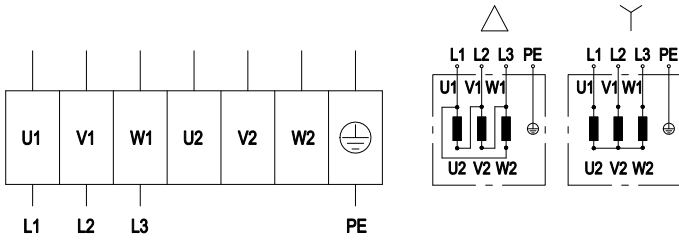

	Three-phase motor	Y	Star connection	Δ	Delta connection
L1	= U1 = blue	L2	= V1 = black	L3	= W1 = brown
U2	= white	V2	= green	W2	= yellow
PE	PE (green/yellow)				



# AC axial fan

straight blades (A series), single inlet  
with guard grille for full nozzle

## Charts: Air flow 50 Hz

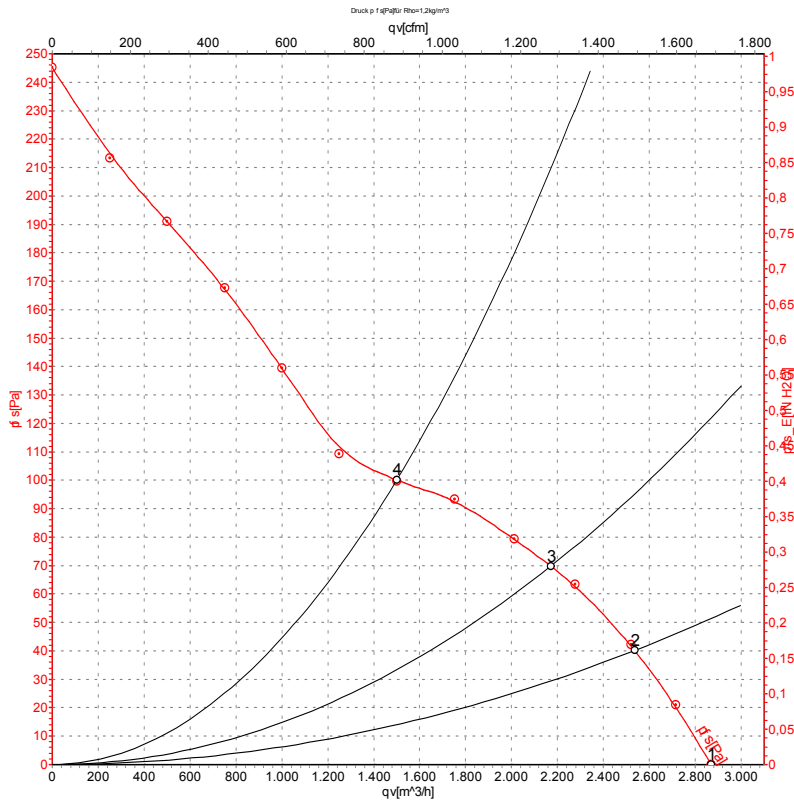

Measurement: LU-64797

Air performance measured as per ISO 5801 Installation category A. For detailed information on the measuring set-up, please contact ebm-papst. Suction-side noise levels: LwA measured as per ISO 13347 / LpA measured with 1m distance to fan axis. The values given are valid under the measuring conditions mentioned above and may vary according to the actual installation situation. With any deviation from the standard set-up, the specific values have to be checked and reviewed with the unit installed.

## Measured values

	U	f	n	P <sub>e</sub>	I	qv	p <sub>fs</sub>
	V	Hz	min <sup>-1</sup>	W	A	m <sup>3</sup> /h	Pa
1	400	50	1420	128	0.39	2870	0
2	400	50	1405	141	0.40	2535	40
3	400	50	1395	150	0.41	2170	70
4	400	50	1385	158	0.41	1500	100

U = Supply voltage · f = Frequency · n = Speed · P<sub>e</sub> = Power input · I = Current draw · qv = Air flow · p<sub>fs</sub> = Pressure increase



# AC axial fan

straight blades (A series), single inlet  
with guard grille for full nozzle

## Charts: Air flow 60 Hz

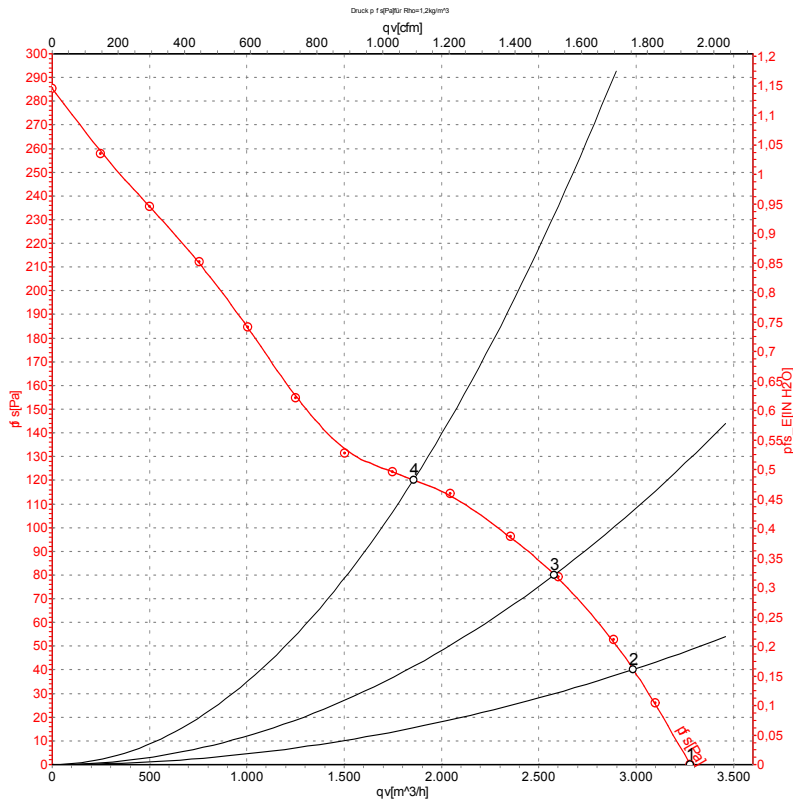

Measurement: LU-64798

Air performance measured as per ISO 5801 Installation category A. For detailed information on the measuring set-up, please contact ebm-papst. Suction-side noise levels: L<sub>wA</sub> measured as per ISO 13347 / L<sub>pA</sub> measured with 1m distance to fan axis. The values given are valid under the measuring conditions mentioned above and may vary according to the actual installation situation. With any deviation from the standard set-up, the specific values have to be checked and reviewed with the unit installed.

## Measured values

	U	f	n	P <sub>e</sub>	I	qv	p <sub>fs</sub>
	V	Hz	min <sup>-1</sup>	W	A	m³/h	Pa
1	400	60	1620	169	0.36	3280	0
2	400	60	1605	185	0.36	2985	40
3	400	60	1580	202	0.38	2580	80
4	400	60	1560	217	0.39	1855	120

U = Supply voltage · f = Frequency · n = Speed · P<sub>e</sub> = Power input · I = Current draw · qv = Air flow · p<sub>fs</sub> = Pressure increase

