

Nominal data

Type	A4E450-AO09-01		
Motor	M4E094-HA		
Phase		1~	1~
Nominal voltage	VAC	230	230
Frequency	Hz	50	60
Type of data definition		ml	ml
Valid for approval / standard		CE	CE
Speed	min ⁻¹	1310	1390
Power input	W	490	650
Current draw	A	2.36	2.96
Motor capacitor	µF	10	10
Capacitor voltage	VDB	400	400
Max. back pressure	Pa	125	115
Min. ambient temperature	°C	-40	-40
Max. ambient temperature	°C	65	55
Starting current	A	6.3	5.6

ml = Max. load · me = Max. efficiency · fa = Running at free air · cs = Customer specs · cu = Customer unit
Subject to alterations

Data according to ErP directive

Installation category	A
Efficiency category	Static
Variable speed drive	No
Specific ratio*	1.00

* Specific ratio = $1 + p_g / 100\,000\text{ Pa}$

		Actual	Request 2013	Request 2015
Overall efficiency η_{es}	%	31.7	27.7	31.7
Efficiency grade N		40	36	40
Power input P_e	kW	0.48		
Air flow q_v	m ³ /h	4420		
Pressure increase p_{fs}	Pa	122		
Speed n	min ⁻¹	1315		

Data definition with optimum efficiency.
The ErP data is determined using a motor-impeller combination in a standardised measurement configuration.

Technical features

Mass	7.5 kg
Size	450 mm
Surface of rotor	Coated in black
Material of terminal box	ABS plastic, black
Material of blades	Press-fitted sheet steel blank, sprayed with PP plastic
Number of blades	5
Direction of air flow	"V"
Direction of rotation	Counter-clockwise, seen on rotor
Type of protection	IP 54
Insulation class	"F"
Humidity class	F4-1
Max. permissible ambient motor temp. (transp./ storage)	+80 °C
Min. permissible ambient motor temp. (transp./storage)	-40 °C
Mounting position	Shaft horizontal or rotor on bottom; rotor on top on request
Condensate discharge holes	Rotor-side
Operation mode	S1
Motor bearing	Ball bearing
Touch current acc. IEC 60990 (measuring network Fig. 4, TN system)	<= 3.5 mA
Electrical leads	Via terminal box, integrated capacitor connected via terminal box
Motor protection	Thermal overload protector (TOP) brought out
Protection class	I (if protective earth is connected by customer)
Product conforming to standard	EN 60034-1 (2004); CE
Approval	CCC

Product drawing

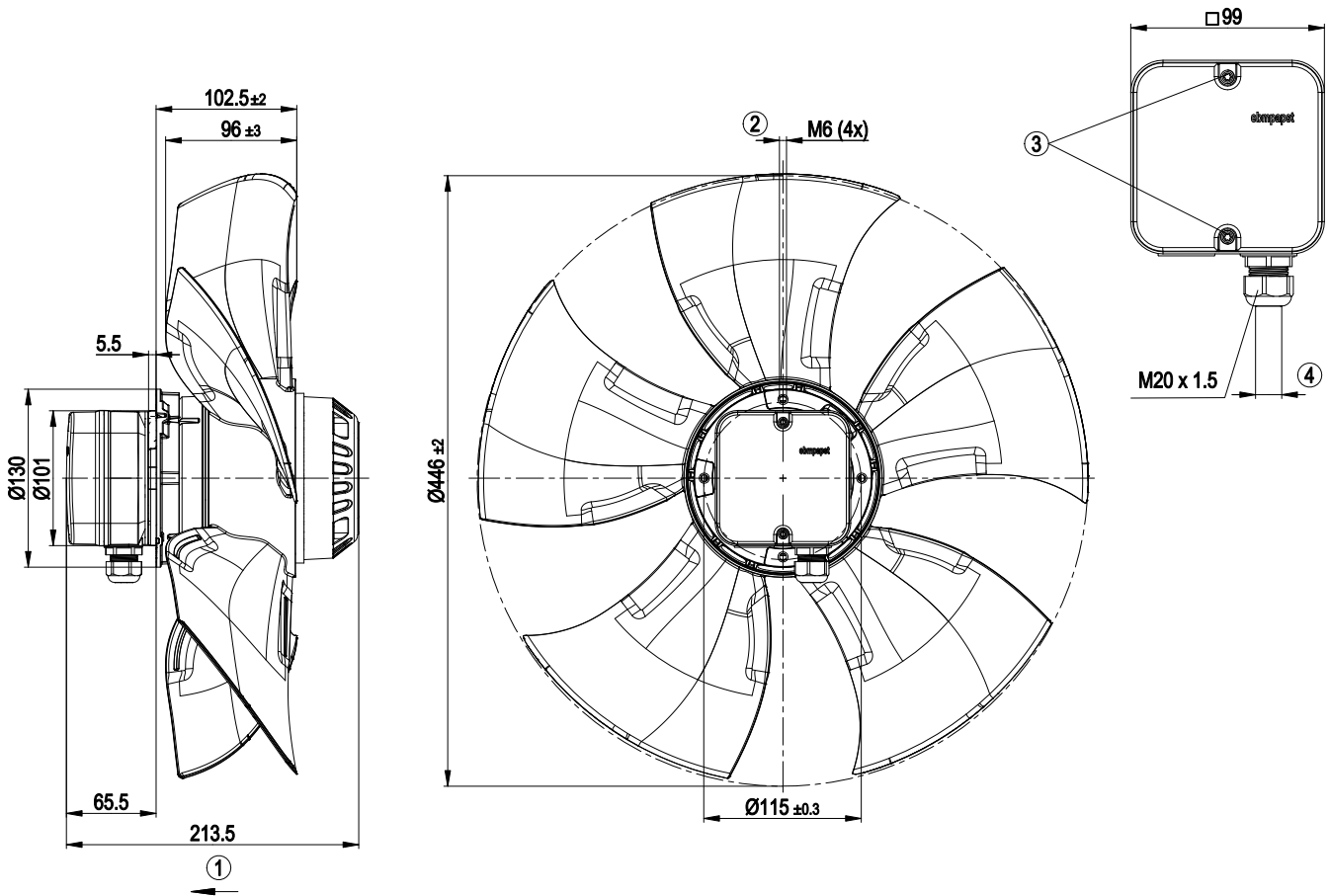

1	Direction of air flow "V"
2	Depth of screw max. 12 mm
3	Tightening torque 0.8 ± 0.15 Nm
4	Cable diameter: min. 6 mm, max. 12 mm, tightening torque: 2 ± 0.3 Nm

Connection screen

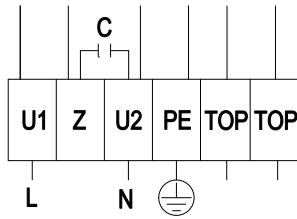

L	= U1 = blue	Z	brown	N	= U2 = black
PE	green / yellow	TOP	grey		

Charts: Air flow 50 Hz

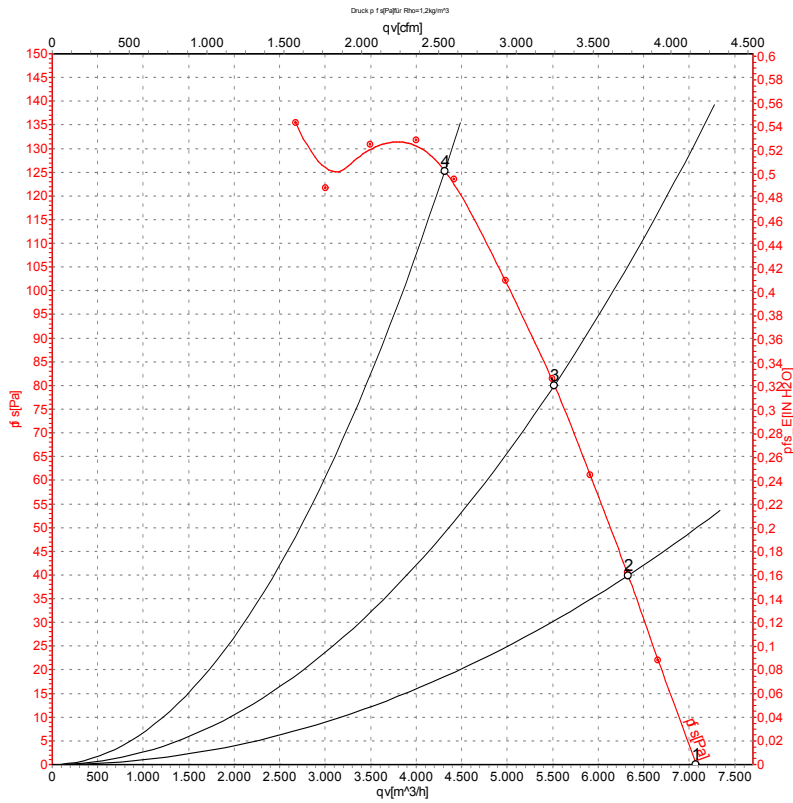

Measurement: LU-106846

Air performance measured as per ISO 5801 Installation category A. For detailed information on the measuring set-up, please contact ebm-papst. Suction-side noise levels: LwA measured as per ISO 13347 / LpA measured with 1m distance to fan axis. The values given are valid under the measuring conditions mentioned above and may vary according to the actual installation situation. With any deviation from the standard set-up, the specific values have to be checked and reviewed with the unit installed.

Measured values

	U	f	n	Pe	I	LpA _{in}	LwA _{in}	LwA _{out}	qv	p _{fs}
	V	Hz	min ⁻¹	W	A	dB(A)	dB(A)	dB(A)	m ³ /h	Pa
1	230	50	1350	430	2.10	63	69	70	7070	0
2	230	50	1340	447	2.16	62	68	69	6330	40
3	230	50	1325	470	2.26	62	68	69	5520	80
4	230	50	1310	490	2.36	62	68	69	4315	125

U = Supply voltage · f = Frequency · n = Speed · Pe = Power input · I = Current draw · LpA_{in} = Sound pressure level inlet side · LwA_{in} = Sound power level inlet side · LwA_{out} = Sound power level outlet side
 qv = Air flow · p_{fs} = Pressure increase



Charts: Air flow 60 Hz

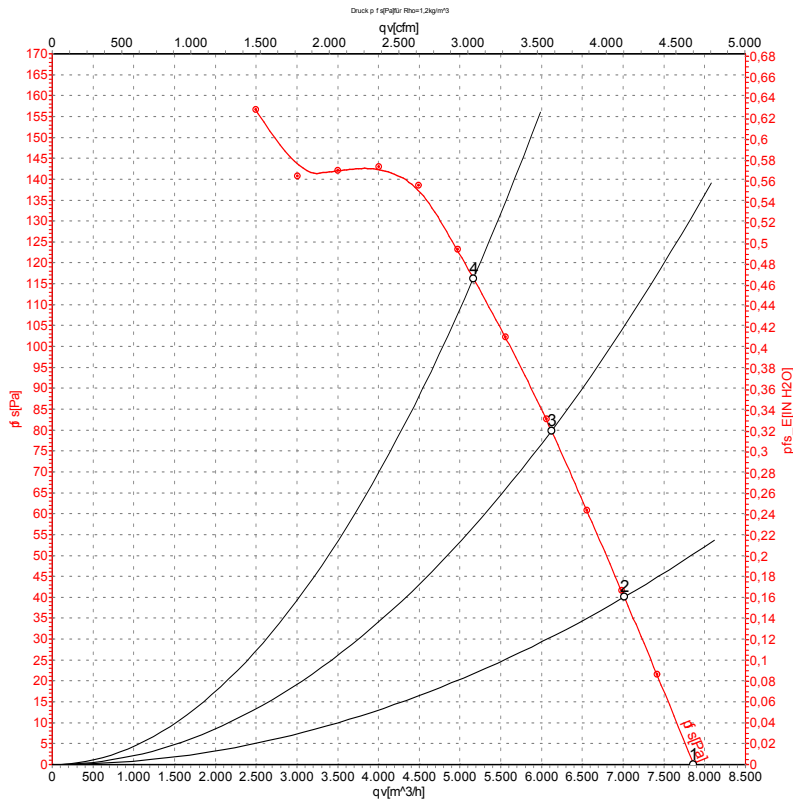

Measurement: LU-106848

Air performance measured as per ISO 5801 Installation category A. For detailed information on the measuring set-up, please contact ebmpapst. Suction-side noise levels: L_{wA} measured as per ISO 13347 / L_{pA} measured with 1m distance to fan axis. The values given are valid under the measuring conditions mentioned above and may vary according to the actual installation situation. With any deviation from the standard set-up, the specific values have to be checked and reviewed with the unit installed.

Measured values

	U	f	n	P _e	I	L _{pA_{in}}	L _{wA_{in}}	L _{wA_{out}}	qv	p _f
	V	Hz	min ⁻¹	W	A	dB(A)	dB(A)	dB(A)	m ³ /h	Pa
1	230	60	1480	600	2.70	65	72	73	7860	0
2	230	60	1455	615	2.76	64	70	71	7015	40
3	230	60	1415	637	2.87	63	70	71	6120	80
4	230	60	1390	650	2.96	62	69	70	5165	115

U = Supply voltage · f = Frequency · n = Speed · P_e = Power input · I = Current draw · L_{pA_{in}} = Sound pressure level inlet side · L_{wA_{in}} = Sound power level inlet side · L_{wA_{out}} = Sound power level outlet side
 qv = Air flow · p_f = Pressure increase

