

## Caratteristiche tecniche

## Technical features

Le caratteristiche principali dei motoriduttori a corrente continua della serie ECMM sono:

The main features of ECMM DC gearmotor range are:

- Alimentazione in bassa tensione 12/24Vcc
- Possibilità di montaggio encoder
- Potenze motore disponibili da 100 a 800W S2
- Magneti in ferrite
- Carcassa in pressofusione di alluminio nelle grandezze 026, 030, 040, 050, 063, 075, 090 e 110. La grandezza 130 è costruita con carcassa in ghisa
- Lubrificazione permanente con olio sintetico
- Low voltage power supply 12/24Vdc
- Suitable for encoder assembly
- Motor power ratings available from 100 up to 800W S2
- Ferrite magnets
- Die cast aluminium housing on sizes 026, 030, 040, 050, 063, 075, 090 and 110. Cast iron housing on size 130
- Permanent synthetic oil long life lubrication

## Designazione

## Classification

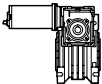
MOTORIDUTTORE / GEARMOTOR														
ECMM	100/026/026					U	150	SZDX	BRSX	90	B3	UB1	120	VS1
Tipo Type	Grandezza Size					Versione Version	Rapporto Ratio	Albero di uscita Output shaft	Braccio di reazione Torque arm	Angolo Angle	Pos. di montaggio Mounting position	Esecuzione di montaggio Mounting execution	Versione motore Motor version	Opzioni Options
	070/026/026	100/026/026	180/026/040	250/030/040	350/030/040	U	vedi tabelle	<b>SZDX</b> <b>SZSX</b> <b>DZ</b>	<b>BRDX</b> <b>BRSX</b>	0°	<b>B3</b> <b>B8</b> <b>B6</b> <b>B7</b> <b>V5</b> <b>V6</b>	<b>UB1</b> <b>UB2</b> <b>US1</b> <b>US2</b> <b>UV1</b> <b>UV2</b> <b>UC1</b> <b>UC2</b>	<b>120</b> <b>240</b> <b>24E</b>	<b>VS1</b> <b>VS2</b>
	070/026/030	100/026/030	180/026/050	250/030/050	350/030/050	FD								
	070/026/040	100/026/040	180/030/040	250/030/063	350/030/063	FS								
	070/026/050	100/026/050	180/030/050	250/040/075	350/040/075	FLD								
	070/030/040	100/030/040	180/030/063	250/040/090	350/040/090	FLS								
	070/030/050	100/030/050	180/040/075	250/050/110	350/050/110	FBD								
	070/030/063	100/030/063	180/040/090		350/063/130	FBS								
	070/040/075	100/040/075	180/050/110											
	070/040/090	100/040/090												

Versione Riduttore  
Gearbox Version

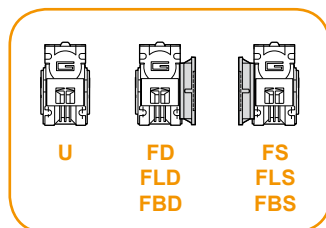

Albero di uscita  
Output shaft

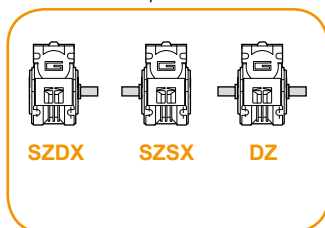

Braccio di reazione  
Torque arm

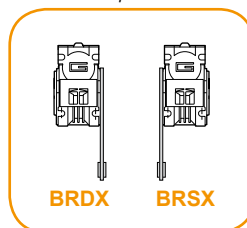

Angolo  
Angle

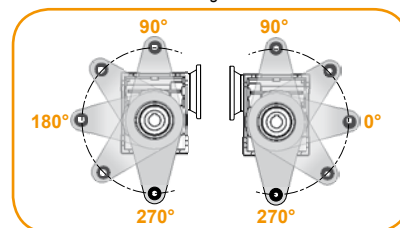

## Simbologia

## Symbols

$n_1$ [min <sup>-1</sup> ]	Velocità in ingresso / Input speed	$M_2$ [Nm]	Coppia in uscita in funzione di $P_1$ / Output torque referred to $P_1$
$n_2$ [min <sup>-1</sup> ]	Velocità in uscita / Output speed	sf	Fattore di servizio / Service factor
i	Rapporto di riduzione / Ratio	$R_2$ [N]	Carico radiale ammissibile in uscita / Permitted output radial load
$P_1$ [kW]	Potenza in entrata / Input power	$A_2$ [N]	Carico assiale ammissibile in uscita / Permitted output axial load

## Esecuzioni di montaggio

## Mounting executions

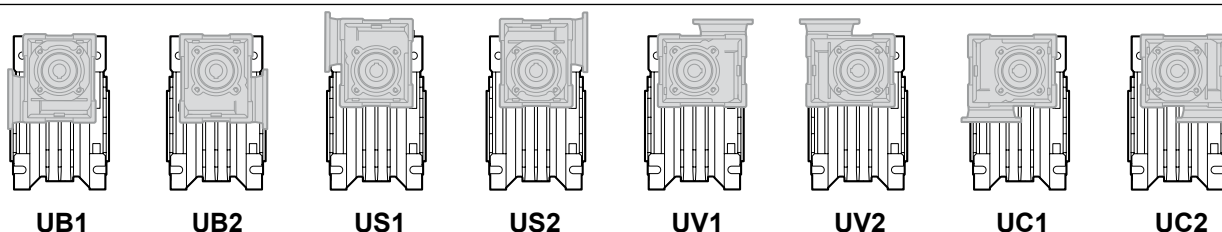

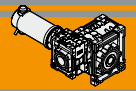

Combinazioni rapporti

Combination ratio

CMM 026/026 - CMM 026/030 - CMM 026/040 - CMM 026/050												
i (i <sub>1</sub> x i <sub>2</sub> )												
	150	225	300	450	600	900	1200	1500	1800	2400	3000	3600
i <sub>1</sub>	10	15	10	15	20	30	40	50	60	60	60	60
i <sub>2</sub>	15	15	30	30	30	30	30	30	30	40	50	60

CMM 030/040 - CMM 030/050 - CMM 030/063 - CMM 040/075 - CMM 040/090 - CMM 050/110 - CMM 063/130																
i (i <sub>1</sub> x i <sub>2</sub> )																
	75	100	150	200	250	300	400	500	600	750	900	1200	1500	1800	2400	3000
i <sub>1</sub>	7.5	10	10	10	10	10	10	10	20	25	30	40	50	60	60	60
i <sub>2</sub>	10	10	15	20	25	30	40	50	30	30	30	30	30	30	40	50

Lubrificazione

Lubrication

	CMM											
	026/026	026/030	026/040	026/050	030/040	030/050	030/063	040/075	040/090	050/110	063/130	
①	026			030			040		050		063	
	Lubrificazione a vita / Life lubricated											
②	026	030	040	050	040	050	063	075	090	110	130	
	Lubrificazione a vita / Life lubricated											

Posizioni di montaggio / Mounting positions

CM 026-030-040-050-063-075-090-110

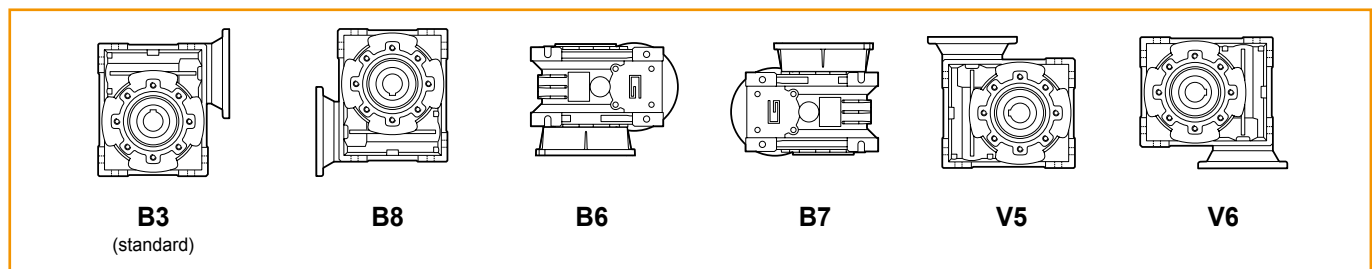

CM 130

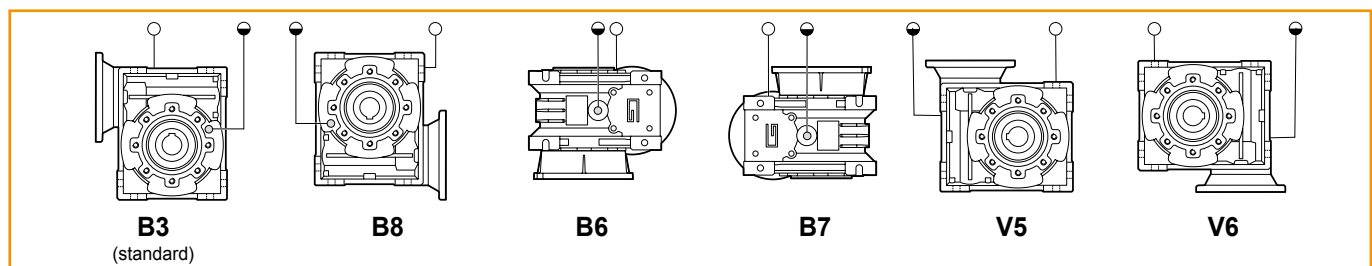



○ Sfiato e tappo di riempimento / Breather and filling plug  
● Livello olio / Oil level plug

	Quantità di olio (litri) / Oil quantity (litres)					
	B3	B8	B6	B7	V5	V6
CM026				0.02		
CM030				0.03		
CM040				0.07		
CM050				0.1		
CM063				0.25		
CM075				0.4		
CM090				0.7		
CM110				1.1		
CM130	4.5	3.3	3.5	3.5	4.5	3.3

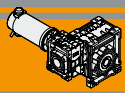
Lubrificati a vita  
Life Lubrication

**Dati tecnici per servizio S2****Technical data for S2 duty**

$P_1$ [W]	$n_2$ [min <sup>-1</sup> ]	$M_2$ [Nm]	sf	i		Versione motore Motor version	$P_1$ [W]	$n_2$ [min <sup>-1</sup> ]	$M_2$ [Nm]	sf	i		Versione motore Motor version					
<b>100</b>							<b>100</b>											
(3000 min <sup>-1</sup> )	<b>20.0</b>	26	1.0	150	ECMM 070/026/026	120/240	(3000 min <sup>-1</sup> )	<b>40.0</b>	15	5.5	75	ECMM 070/030/040	120/240					
	<b>13.3</b>	26	1.0	225					<b>30.0</b>	20	4.2			100				
	<b>10.0</b>	27	1.0	300					<b>20.0</b>	28	3.2			150				
	<b>6.7</b>	27	1.0	450					<b>15.0</b>	36	2.1			200				
	<b>5.0</b>	27	1.0	600					<b>12.0</b>	43	1.6			250				
	<b>3.3</b>	27	1.0	900					<b>10.0</b>	46	2.0			300				
	<b>2.5</b>	27	1.0	1200					<b>7.5</b>	55	1.3			400				
	<b>2.0</b>	27	1.0	1500					<b>6.0</b>	63	1.1			500				
	<b>1.7</b>	27	1.0	1800					<b>5.0</b>	86	1.0			600				
	<b>1.3</b>	22	1.0	2400					<b>4.0</b>	103	0.9			750				
	<b>1.0</b>	20	1.0	3000					<b>3.3</b>	118	0.8			900				
	<b>0.8</b>	18	1.0	3600					<b>2.5</b>	74	1.0			1200				
									<b>2.0</b>	90	1.0			1500				
	<b>20.0</b>	26	1.5	150			ECMM 070/026/030	120/240	<b>1.7</b>	90	1.0			1800				
	<b>13.3</b>	39	1.0	225							<b>1.3</b>			74	1.0	2400		
	<b>10.0</b>	40	1.0	300					<b>1.0</b>	68	1.0	3000						
	<b>6.7</b>	40	1.0	450														
	<b>5.0</b>	40	1.0	600					<b>15.0</b>	36	3.8	200	ECMM 070/030/050	120/240				
	<b>3.3</b>	40	1.0	900					<b>12.0</b>	43	2.9	250						
	<b>2.5</b>	40	1.0	1200					<b>10.0</b>	46	3.5	300						
	<b>2.0</b>	40	1.0	1500					<b>7.5</b>	57	2.4	400						
	<b>1.7</b>	40	1.0	1800					<b>6.0</b>	64	2.0	500						
	<b>1.3</b>	34	1.0	2400					<b>5.0</b>	87	1.9	600						
	<b>1.0</b>	30	1.0	3000					<b>4.0</b>	105	1.5	750						
	<b>0.8</b>	27	1.0	3600					<b>3.3</b>	120	1.4	900						
									<b>2.5</b>	146	0.9	1200						
	<b>20.0</b>	27	3.2	150	ECMM 070/026/040	120/240			<b>2.0</b>	175	0.9	1500						
	<b>13.3</b>	40	2.2	225							<b>1.7</b>	201			0.8	1800		
	<b>10.0</b>	45	2.0	300					<b>1.3</b>	135	1.0	2400						
	<b>6.7</b>	66	1.4	450					<b>1.0</b>	125	1.0	3000						
	<b>5.0</b>	85	1.1	600														
	<b>3.3</b>	90	1.0	900					<b>4.0</b>	109	2.8	750			ECMM 070/030/063	120/240		
	<b>2.5</b>	90	1.0	1200					<b>3.3</b>	124	2.5	900						
	<b>2.0</b>	90	1.0	1500					<b>2.5</b>	149	1.7	1200						
	<b>1.7</b>	90	1.0	1800					<b>2.0</b>	181	1.7	1500						
	<b>1.3</b>	74	1.0	2400					<b>1.7</b>	208	1.5	1800						
	<b>1.0</b>	68	1.0	3000					<b>1.3</b>	249	1.0	2400						
	<b>0.8</b>	62	1.0	3600					<b>1.0</b>	288	0.8	3000						
	<b>20.0</b>	28	5.7	150			ECMM 070/026/050	120/240	<b>2.5</b>	163	2.6	1200	ECMM 070/040/075	120/240				
	<b>13.3</b>	42	3.9	225							<b>2.0</b>	202					2.5	1500
	<b>10.0</b>	46	3.5	300					<b>1.7</b>	232	2.2	1800						
	<b>6.7</b>	67	2.4	450					<b>1.3</b>	280	1.5	2400						
	<b>5.0</b>	86	1.9	600					<b>1.0</b>	325	1.2	3000						
	<b>3.3</b>	118	1.4	900														
	<b>2.5</b>	147	1.1	1200					<b>1.3</b>	300	2.5	2400					ECMM 070/040/090	120/240
	<b>2.0</b>	162	1.0	1500					<b>1.0</b>	350	1.8	3000						
	<b>1.7</b>	162	1.0	1800														
	<b>1.3</b>	135	1.0	2400														
	<b>1.0</b>	125	1.0	3000														
	<b>0.8</b>	113	1.0	3600														

**Nota:** Verificare sempre che la coppia M2 utilizzata non ecceda il valore indicato nelle caselle in grigio

**Note:** Please check that the output torque M2 does not exceed the value into the grey areas

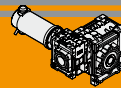

Motori applicabili

IEC Motor adapters

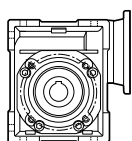
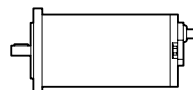
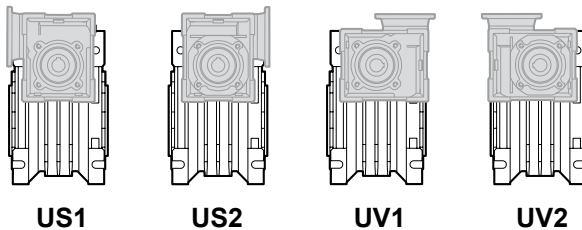

		EC			
		070.120 070.240	100.120 100.240	100.24E	180.120 180.240
<b>CMM</b>	<b>026/026</b>	150 - 3600	150 - 3600	150 - 3600	150 - 3600

150 - 3600

Rapporti di riduzione i  
Ratio i

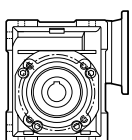
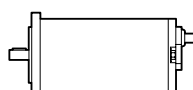
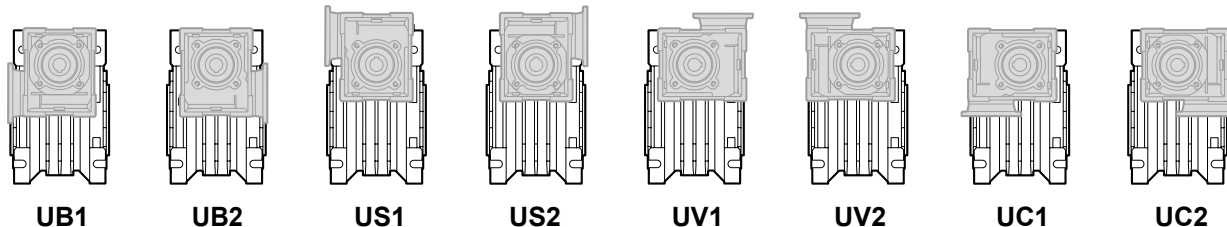

		EC							
		070.120 070.240	100.120 100.240	100.24E	180.120 180.240	180.24E	250.120 250.240	350.120 350.240	600.120 600.240
<b>CMM</b>	<b>026/030</b>	150 - 3600	150 - 3600	150 - 3600	150 - 3600				
	<b>026/040</b>	150 - 3600	150 - 3600	150 - 3600	150 - 3600				
	<b>026/050</b>	150 - 3600	150 - 3600	150 - 3600	150 - 3600				
	<b>030/040</b>	75 - 3000	75 - 3000	75 - 3000	75 - 3000	75 - 1500	75 - 1500	75 - 1500	
	<b>030/050</b>	75 - 3000	75 - 3000	75 - 3000	75 - 3000	75 - 1500	75 - 1500	75 - 1500	
	<b>030/063</b>	75 - 3000	75 - 3000	75 - 3000	75 - 3000	75 - 1500	100 - 1500	75 - 1500	
	<b>040/075</b>	75 - 3000	75 - 3000	75 - 3000	75 - 3000	75 - 3000	200 - 3000	75 - 3000	75 - 1200
	<b>040/090</b>	75 - 3000	75 - 3000	75 - 3000	75 - 3000	75 - 3000	250 - 3000	75 - 3000	75 - 1200
	<b>050/110</b>				1200 - 3000	75 - 3000	500 - 3000	75 - 3000	75 - 3000
	<b>063/130</b>							75 - 3000	75 - 3000

150 - 3600

Rapporti di riduzione i  
Ratio i

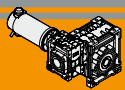

**Dimensioni**

**Dimensions**

CMM..U - CMM..F - CMM..FB - CMM..FL																	
	A	C	D <sub>H8</sub>	E	F	G	G1	H	H1	I	I1	K	L	M	N <sub>h8</sub>	N1	N2
026/026	45	70	12	83	22	47.5	50	35	34	26	26	34	42	55	45	22.5	21
026/030	54	80	14	97	32	47.5	63	40	34	30	26	44	56	65	55	29	21
026/040	70	100	18	121.5	43	47.5	78	50	34	40	26	60	71	75	60	36.5	21
026/050	80	120	25	144	49	47.5	92	60	34	50	26	70	85	85	70	43.5	21
030/040	70	100	18	121.5	43	55	78	50	40	40	30	60	71	75	60	36.5	29
030/050	80	120	25	144	49	55	92	60	40	50	30	70	85	85	70	43.5	29
030/063	100	144	25	174	67	55	112	72	40	63	30	85	104	95	80	53	29
040/075	120	172	28	205	72	70	120	86	50	75	40	90	112	115	95	57	36.5
040/090	140	208	35	238	74	70	140	103	50	90	40	100	130	130	110	67	36.5

CMM..U - CMM..F - CMM..FB - CMM..FL															
	O	P	Q	R	R1	S	T	V	Z	KE	a	b	t	Kg	
026/026	6	—	37	49	49	5	15	21	76	7	—	4	13.8	3.3	
026/030	6.5	75	44	57	49	5.5	22	27	81	M6x10(n.4)	90°	5	16.3	4.1	
026/040	6.5	87	55	71.5	49	6.5	26	35	91.5	M6x8(n.4)	45°	6	20.8	5.2	
026/050	8.5	98	64	84	49	7	30	40	100.5	M8x10(n.4)	45°	8	28.3	6.7	
030/040	6.5	87	55	71.5	57	6.5	26	35	122	M6x8(n.4)	45°	6	20.8	5.6	
030/050	8.5	98	64	84	57	7	30	40	132	M8x10(n.4)	45°	8	28.3	6.7	
030/063	8.5	110	80	102	57	8	36	50	145	M8x14(n.8)	45°	8	28.3	8.7	
040/075	11	140	93	119	71.5	10	40	60	165	M8x14(n.8)	45°	8	31.3	13.7	
040/090	13	160	102	135	71.5	11	45	70	182	M10x18(n.8)	45°	10	38.3	17.3	

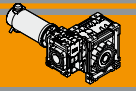

Dimensioni

Dimensions

ECMM070/...U

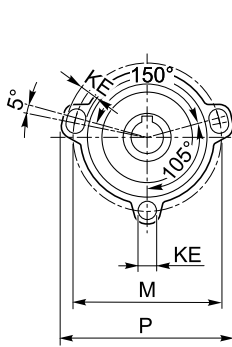
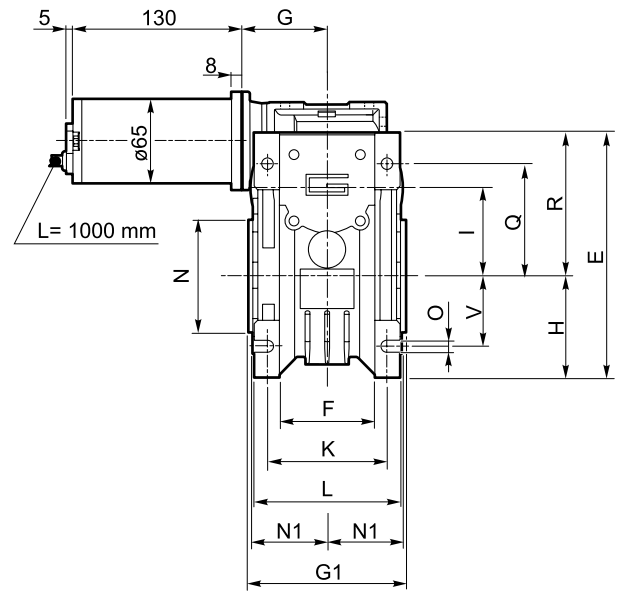
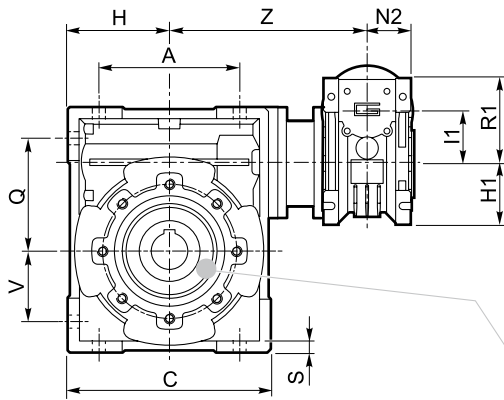

..026/026

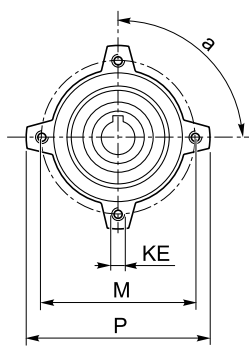

..026/030

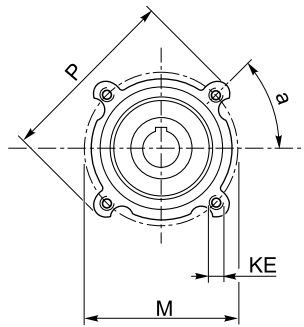

..026/040 ..026/050  
..030/040 ..030/050

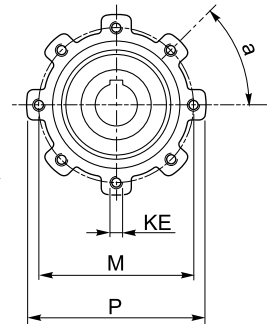

..030/063 ..040/075  
..040/090

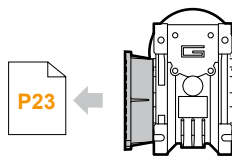

ECMM070/... F  
ECMM070/... FL  
ECMM070/... FB

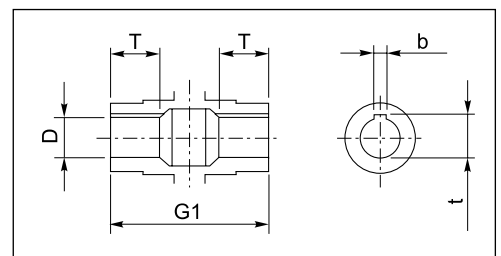

Albero lento cavo / Hollow output shaft